



FLOWTEC®

ISV - INLINE SAMPLING VALVE

ITALPROTEC
INDUSTRIES

ISV: Product Info

Inline Sampling Valves

Inline Sampling Valves ISV Series

for safe and representative sampling of corrosive, aggressive or even toxic media from pipelines, pressurized or at vacuum conditions – without process interruptions.

Modular Design

Sampling Valves ISV Series are available as DIN- or ANSI-valves, with handwheel as per standard. The valves are distinguished by its dead-space-free design as well as the extremely short outlet way for the representative sample.

The sturdy bodies are made of stainless steel casting 1.4408 (CF-8M) or optional with resistant linings and valve spindle encapsulations.



Main Features

- Dead-space-free design, conforming to TA-Luft
- Safe and simple operation by handwheel or with deadman lever (spring to close), lockable
- Installation in any given position
- Corrosion-resistant materials, linings and encapsulations made of PFA or PFA-AS (anti-static)
- Precision sampling for small sample volumes by valve spindle stroke adjustment
- Maintenance-free stuffing box or bellows seal
- Replaceable spindle gasket
- Variety by modular design
- Sizes DN15-150 PN16 resp. 1/2" up to 6"-150lbs
- Face to face according to EN 558-1, range 1

 **Conformity acc. to European Pressure Equipment Directive 97/23/EC (PED)**

Actuator Versions



Options / Accessories

- Bodies with heating jacket
- Needle adapter for lab bottle with septum
- Bottle support, adjustable
- Safety cabinet with inspection windows
- Flange versions: groove, PN40, ANSI 300lbs, clamp or with buttwelding ends
- Handwheel spring to close FC
- Vertical adapter, sealing plug, activ. carbon filter
- Metal safety basket, sampling collector
- Pneum. linear stroke actuator, single-acting FC

Operating Conditions

- Temperature range from -40°C (-40°F) up to +200°C (392°F) (depending on selected materials)
- Line pressure from 0.1 mbar up to 16 bar (232 psi)

Testing / Marking

- Pressure- and tightness testing acc. to EN 12266-1, leakage rate A, and spark testing at 35 kV to assure lining integrity. Marking of valves on body and stainless steel name plate acc. to EN 19.
- Material- resp. test certificate acc. to EN 10204-3.1

Construction of Valve

Body made of stainless steel casting 1.4408 (CF-8M) or with linings made of PFA or PFA-AS (anti-static), wall thickness min. 3 mm.
Flanges acc. to EN 1092 or ASME B16.5

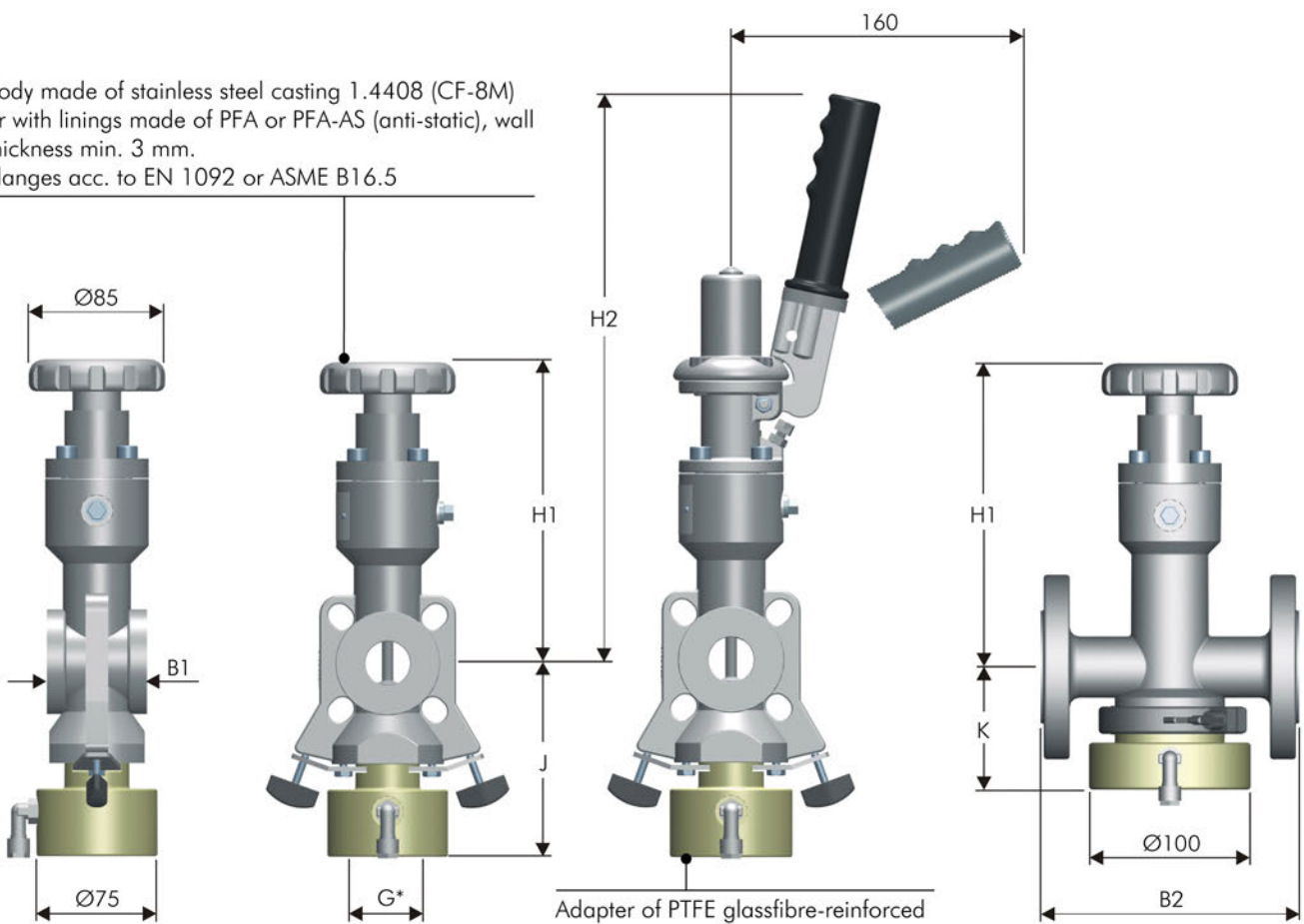

Technical Data Dimensions in mm

■ PFA-lined available

DN	B1 DIN/ANSI	B2 DIN	B2 ANSI	H1	H2	J	K	Wafer-style Valve		Flanged Valve	
								Kg Handwheel	Kg Lever (spring)	Kg Handwheel	Kg Lever (spring)
15/1/2"	-	160	160	194	353	-	70	-	-	4.9	5.8
20/3/4"	-	160	160	194	353	-	70	-	-	4.9	5.8
25/1"	62	160	165	188	347	121	76	4.1	5.0	5.9	6.8
40/1 1/2"	62	200	165	196	355	128	83	4.7	5.6	8.1	9.0
50/2"	62	230	178	202	361	134	89	5.4	6.3	9.4	10.3
80/3"	62	310	203	229	388	148	103	5.9	6.8	14.6	15.5
100/4"	62	350	229	246	405	160	-	14.2	15.1	19.9	20.8
150/6"	62	480	267	264	429	185	-	20.5	21.4	28.5	29.4

Face to face B acc. to DIN EN 558-1 range 1 resp. range 3 and ASME B16.10 G*: Standard threads for bottle GL 32 or GI 45 acc. to DIN 168-1

Operating Conditions

- Temperature range from -40°C (-40°F) up to +200°C (392°F) (depending on selected materials)
- Line pressure from 0.1 mbar up to 16 bar (232 psi)

Testing / Marking

- Pressure- and tightness testing acc. to EN 12266-1, leakage rate A, and spark testing at 35 kV to assure lining integrity. Marking of valves on body and stainless steel name plate acc. to EN 19.
- Material- resp. test certificate acc. to EN 10204-3.1

Flanged Valve – with Handwheel spring to close FC

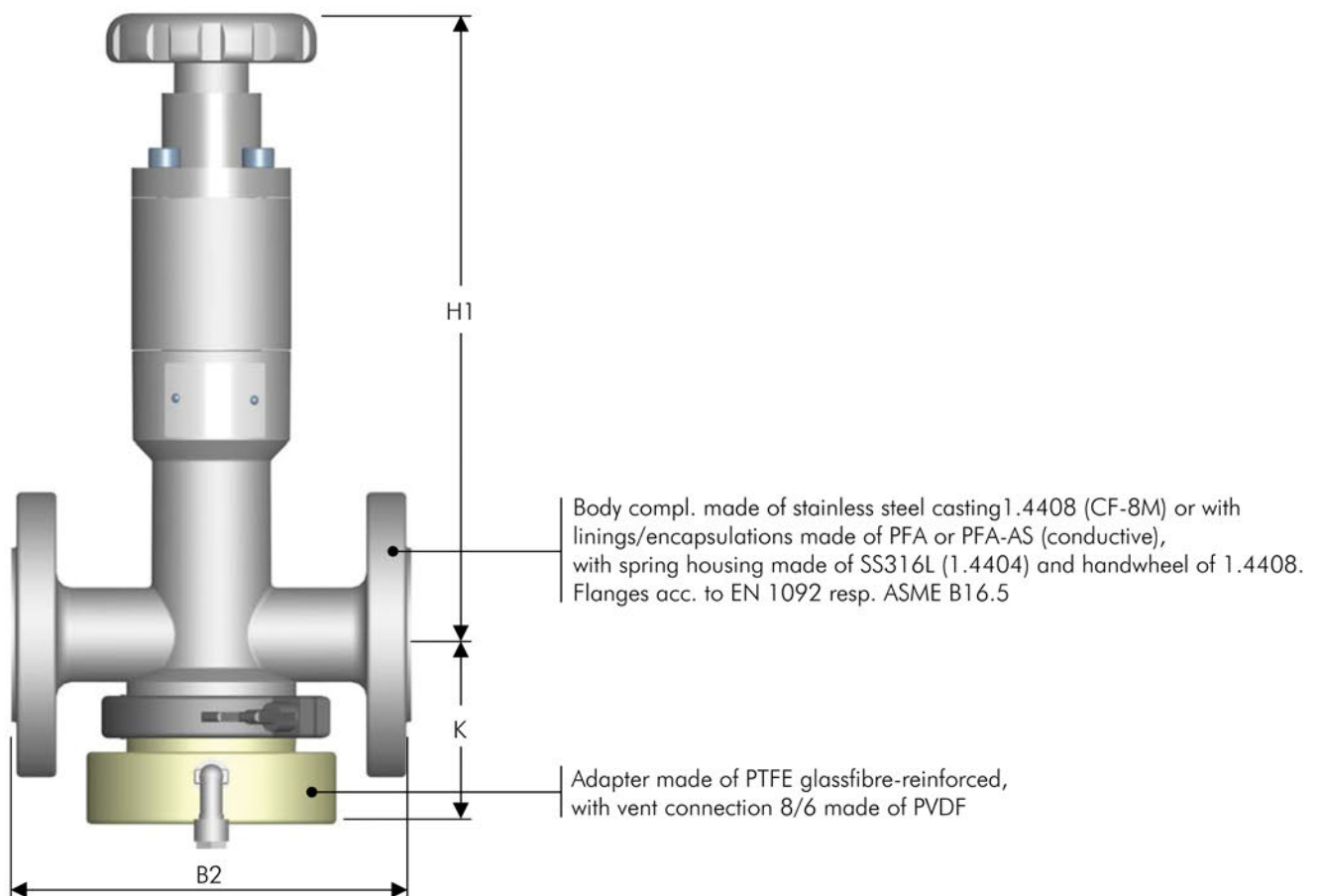

Technical Data Dimensions in mm

Size ND	B2 DIN	B2 ANSI	H1	K	Kg DIN
15/1/2"	160	160	255	70	6.8
20/3/4"	160	160	255	70	6.9
25/1"	160	165	249	76	7.8
40/1 1/2"	200	165	257	83	10.8
50/2"	230	178	263	89	11.8
80/3"	310	203	290	103	16.8
100/4"	350	229	307	116	22.3
150/6"	480	267	325	134	30.9

Face to face B acc. to DIN EN 558-1 range 1 resp. range 3 and ASME B16.10
 Standard threads for lab bottles GL32 / 45 acc. to DIN 168-1

Pressure/Temperature Diagram

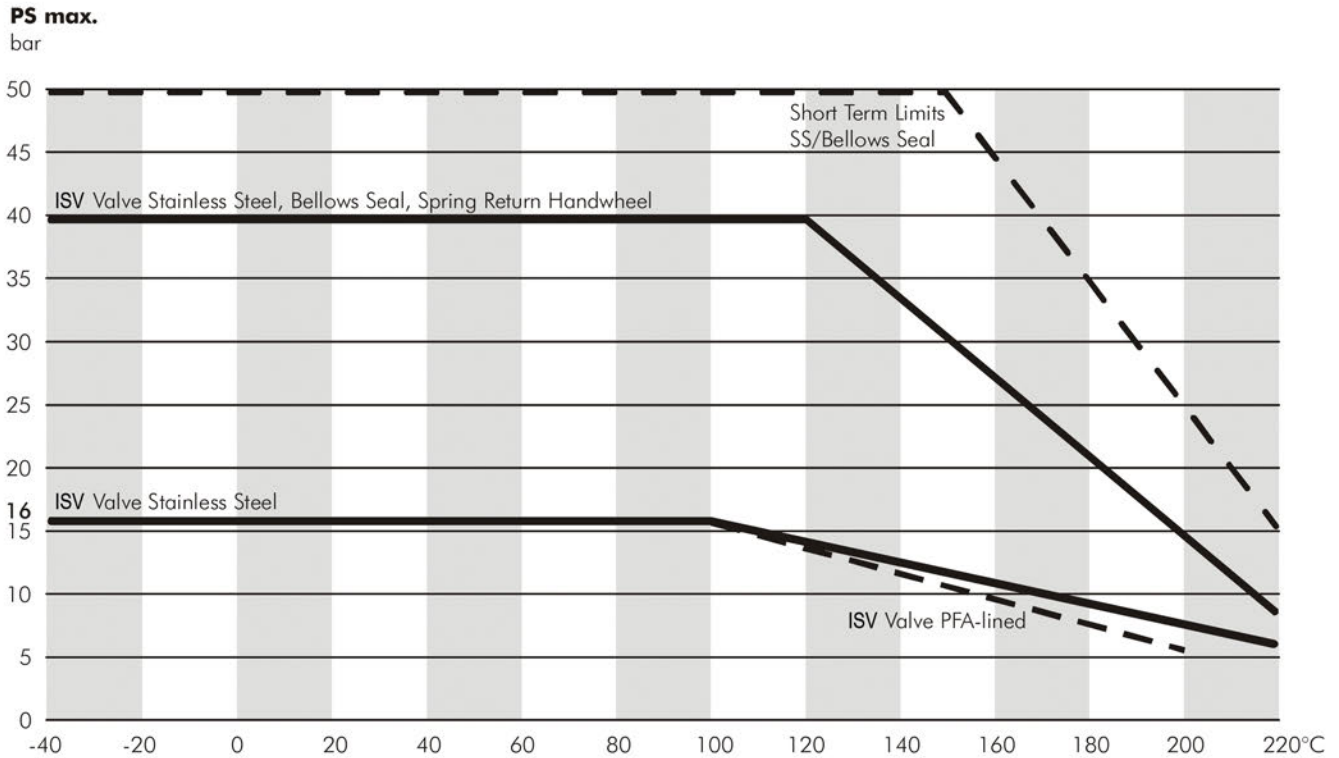

Operating Principle ISV Series (Sampling under pressure, with bottle)

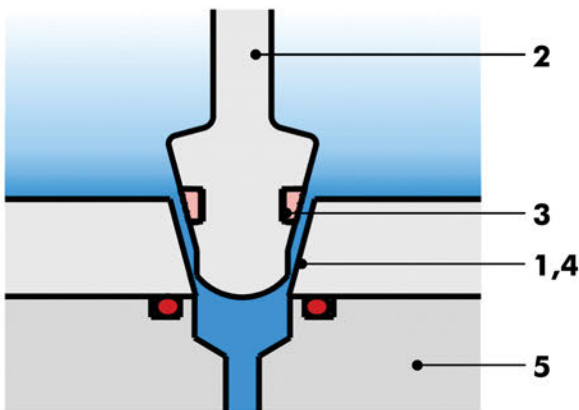

Manual Operation with handwheel or deadman lever

The valve is installed into pipeline either horizontally or vertically.

Media flows through the valve body (1) around the valve spindle (2), equipped with a resistant gasket (3).

By operating handwheel counter-clockwise (or lifting/pulling deadman lever), the valve spindle is lifted out of the tapered valve seat (4) and a representative sample will flow into the attached lab bottle. Trapped air inside the bottle escapes through the vent connection of the adapter (5), sealed by a FEP-encapsulated O-ring.

When the bottle contains the required sample volume, the handwheel is now operated clockwise, which in turn pushes the valve spindle back into the valve seat.

The valve is 100% dead-space-free again.

Valves with Collector (SC) or Piston Injector (PI)

For critical and heavy duty applications, a sampling collector or a piston injector is used in place of the standard adapter with lab bottle.

Available with outlet nozzle/safety cap and lab holder.

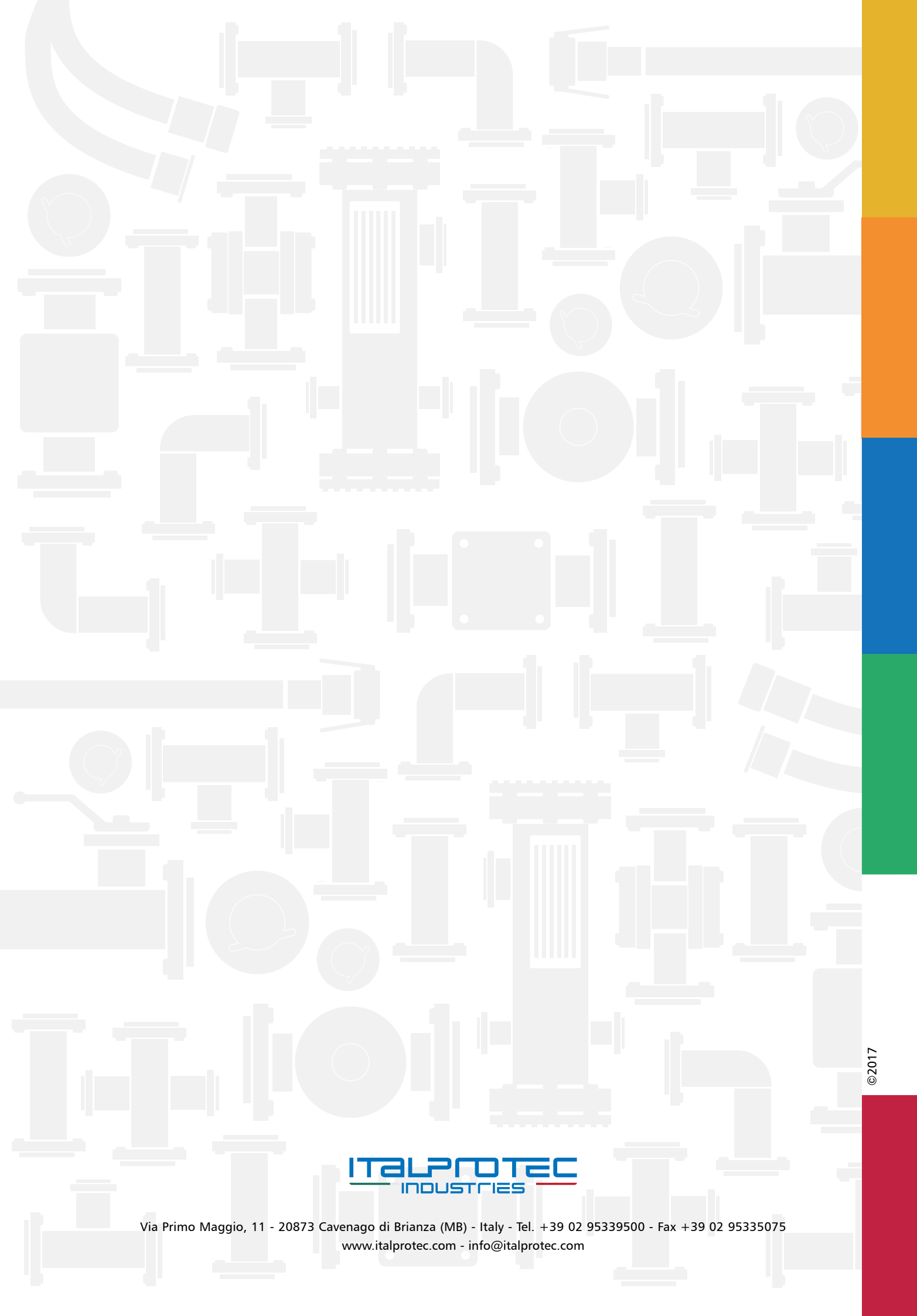

ITALPROTEC
INDUSTRIES

Via Primo Maggio, 11 - 20873 Cavenago di Brianza (MB) - Italy - Tel. +39 02 95339500 - Fax +39 02 95335075
www.italprotec.com - info@italprotec.com