

ACCIAIO

STEEL

I materiali standard di costruzione corrispondono alle normative internazionali.

Esecuzioni in acciaio inossidabile o acciaio per basse temperature od altri materiali si forniscono a richiesta.

The standard construction materials are according to international norms.

Stainless steel, low temperature steel or other materials available on request.

Componente - Component	Materiale - Material	Normativa - Norm
Tubi - Pipes	ASTM A1036 Gr. B	ANSI B 36.10
Flange - Flanges	ASTM A105	ANSI B 16.5
	ASTM A305	ANSI B 16.5
Collarini, stub ends Plate collars, stub ends	ASTM A216 WCB	ANSI B 16.5
	ASTM A105	ANSI B 16.5
Curve, tee, riduzioni Elbows, tees, reducers	ASTM A216 WCB	ANSI B 16.28 - ANSI B 16.9
	ASTM A234 WCB	ANSI B 16.28 - ANSI B 16.9
	ASTM A105	ANSI B 16.28 - ANSI B 16.9
Flange ridotte - Reducing flanges	ASTM A105	ANSI B 16.5
	ASTM A522	ANSI B 16.5

DIMENSIONI E TOLLERANZE

DIMENSIONS AND TOLERANCES

Tutti i tubi vengono forniti di serie con una flangia fissa ed una libera; i raccordi possono essere forniti sia con flange fisse che con flange libere.

Le dimensioni e le tolleranze dei tubi e dei raccordi corrispondono alla normativa ASTM F 1545 ed ANSI B16.5. Per i diametri esterni è ammessa una deviazione massima del -5%.

Raccordi ibridi con flange e dimensioni non corrispondenti alla normativa ANSI B16.5 sono fornibili a richiesta.

All flanged pipes have a loose flange and a fixed flange, fittings are available with fixed or loose flanges.

Dimensional tolerances on the finished products according to ASTM F1545 and B16.5.

The maximal allowed deviation for the outside diameter is -5%.

Non standard items are available on request.

Lunghezza - Length	10÷40 mm	50÷100 mm	≤ 315 mm	315÷1000 mm	1000÷6000 mm
Tubi - Flanged pipes	-	-	± 3,2	± 3,2	± 3,2
Distanziali - Spacers	0	0	-	-	-
	-2	-3	-	-	-

Scartamento - Face to face	≤ DN 4"	DN 5"÷10"	DN 12"	≤ DN 12"
Raccordi ¹ - Fittings ¹	± 1,5	± 1,5	± 3,0	-
Flange ridotte	-	-	-	0
Reducing flanges	-	-	-	+3

1) Per i raccordi ridotti si applica la tolleranza del diametro maggiore.

1) For reduced fittings, the larger nominal size tolerance is applied.

FORI DI VENTILAZIONE

VENT HOLES

Tutti i componenti rivestiti, ad eccezione di alcune flange ridotte e delle flange cieche, sono provvisti di fori di ventilazione di circa 3 mm di diametro. Tali fori, oltre ad evitare lo stazionamento dell'aria tra l'acciaio ed il rivestimento, servono ad indicare la tenuta nella fase di collaudo e le eventuali perdite durante il funzionamento. Fori di ventilazione con prolunga filettata vengono eseguiti a richiesta.

All lined components are provided with 3 mm diameter vent holes with exception of some reducing flanges and blind flanges.

These holes avoid the retention of air between steel and liner and indicate tightness during the inspection test and the possible leak when working.

Vent holes extensions with an internal thread available on request.

SABBIATURA E VERNICIATURA

EXTERNAL SURFACE

Le superfici esterne delle tubazioni e dei raccordi sono sabbiate con grado SA 2,5 e trattate con zincate inorganico spessore 75 µ. Verniciature secondo altre specifiche vengono eseguite a richiesta.

The external surfaces of flanged pipes and fittings are sandblasted (SA 2,5) and coated with inorganic zinc paint with thickness of 75 µ. Treatment according to customer specifications available on request.

L'elevato standard qualitativo dei prodotti prevede l'impiego di **resine vergini non rigenerate**.

PTFE vergine

In funzione del diametro delle tubazioni e delle curve viene utilizzato esclusivamente PTFE vergine estruso da pasta o stampato isostaticamente.

Il PTFE non è un termoplastico.

PTFE estruso da pasta secondo ASTM D4895

Questo processo si divide in tre stadi e permette la realizzazione di tubi e curve. Nella prima fase si ha la preformatura di un manicotto stampato con polvere di PTFE lubrificata. Il manicotto viene poi inserito nella camera di un estrusore dove, per mezzo di una spinta costante, si ottiene il tubo in PTFE che viene successivamente sinterizzato in forno ad una temperatura di circa 380°C. Questo procedimento conferisce al prodotto finito uno spessore uniforme e perfettamente omogeneo. Con l'aggiunta iniziale di carbon black nella polvere si ottiene il tubo in PTFE nero antistatico.

PTFE stampato isostaticamente secondo ASTM D4894

Questo metodo di rivestimento viene ottenuto esercitando una pressione idrostatica alla polvere di PTFE contenuta tra l'acciaio e lo stampo elastomerico. La pressione applicata allo stampo viene trasmessa in tutte le direzioni alla polvere di PTFE. Una volta pressato il PTFE viene sinterizzato in forno.

PFA vergine secondo ASTM D3307 tipo II

Il PFA è un fluoropolimero termoplastico con proprietà paragonabili a quelle del PTFE. Viene utilizzato per il rivestimento di raccordi, valvole e particolari speciali. Il rivestimento del PFA avviene per iniezione o per trasferimento della massa fusa (transfer moulding) che, sotto pressione, penetra tra l'acciaio ed un apposito stampo.

PVDF secondo ASTM D3222

Il PVDF è un fluoropolimero termoplastico con ottime qualità di resistenza chimica che, in presenza di fluidi quali Fosgene, Cloro o Bromo, risulta essere superiore anche a quella del PTFE e del PFA. Rispetto a questi materiali, il PVDF ha anche una maggiore resistenza all'abrasione; la massima temperatura di impiego è limitata a +135°C, la minima a -12°C. Il processo di ottenimento dei particolari rivestiti è simile a quello del PFA.

PP secondo ASTM D4101 e ASTM D2146

Il Polipropilene è un polimero termoplastico ed ha una buona resistenza chimica alle soluzioni acquose di acidi, basi e sali inorganici. Quando le condizioni di esercizio lo consentono, viene preferito ai materiali precedentemente descritti per il costo inferiore. La temperatura massima di impiego è di +107°C, la minima di -20°C. Le tubazioni e gli elementi in acciaio rivestito in PP non danno luogo ad instabilità dimensionale o spacchi come invece avviene nelle tubazioni esclusivamente in PP od altre plastiche, le quali sono soggette all'invecchiamento provocato dai raggi UV e dagli agenti atmosferici.

The high quality standards of our products are maintained by using **only virgin materials**.

Virgin PTFE

Depending on pipe and elbow diameters, different types of virgin PTFE may be used; paste extruded, isostatic moulded and paste tape wound. PTFE is not a thermoplastic.

Paste extruded PTFE according to ASTM D4895

This process is divided into three stages and makes it possible to manufacture straight tubes and elbows. In the first stage a rod is made from a mixture of lubricated PTFE fine powder. The PTFE rod will be inserted into housing extruder. When the tube is extruded, the sintering process is carried out at approx. 380°C (the lubricant agent is removed at the beginning of the sintering process). Paste extrusion liners can be coloured black when a carbon black filler is used as an extrusion aid, this can be antistatic PTFE.

Isostatic moulded PTFE according to ASTM D4894

This is a technique for preforming PTFE powder by applying hydrostatic pressure to a sealed flexible mould which contains the PTFE powder. The pressure applied to the mould is transmitted to the powder through the flexible mould parts, which are usually elastomeric membranes. Sintering is done after the process moulding.

Virgin PFA according to ASTM D-3307 type II

PFA is a thermoplastic fluoropolymer with the closest properties to PTFE. It is widely used as a lining material for fittings, valves and special parts. PFA lining can be processed by injection or transfer moulding techniques. These methods are based on forming the PFA in molten stage.

PVDF according to ASTM D3222

This thermoplastic fluoropolymer is of excellent quality and can sometimes produce better results than PTFE/PFA in difficult chemical services such as Phosgene, Chlorine and Bromine. Combined with an excellent resistance against abrasion it can, subject to conditions, withstand temperatures up to +135°C, the minimum temperature is -12°C. Processing of PVDF is comparable with PFA processing.

PP according to ASTM D4101 and ASTM D2146

Polypropylene is a thermoplastic polymer and has a good chemical resistance to aqueous solutions of inorganic salts as well as almost all inorganic acids and bases. It can be used in many cases at much lower cost than PTFE/PFA and PVDF; provided temperatures are limited to +107°C, the minimum temperature is -20°C. PP lined steel pipes and fittings are not subject to dimensional instability or cracks as some solid plastic system moreover, also they do not suffer from the aging due to UV rays and weather.

RIVESTIMENTI

LININGS

Permeazione

Permeation

Confronto eseguito fra diversi materiali plastici, su una superficie di 50 cm² con Elio a 2 bar.

Comparison among different kinds of fluoropolymer linings. On a surface 50 cm², Helium at 2 bar.

Materiale <i>Material</i>	Spessore <i>Thickness</i>	Durata del test <i>Time of test</i>	Temperatura <i>Temperature</i>	Permeazione <i>Permeation</i>
PVDF	2,20 mm	382 h	25°C	870
		84 h	85°C	14040
FEP Foglio- Film	1,50 mm	382 h	25°C	4800
		84 h	85°C	55393
PFA Foglio -Film	1,52 mm	382 h	25°C	5315
		84 h	85°C	21971
PTFE Estruso a secco - Ram	2,50 mm	382 h	25°C	5854
		84 h	85°C	44742
PTFE Estruso da pasta - Paste	2,60 mm	382 h	25°C	2216
		84 h	85°C	10782

Proprietà meccaniche

Mechanical properties

Proprietà	Metodo	U.M.	PTFE	PFA	PVDF	PP	Properties
Peso specifico	DIN 53479	g/cm ³	2,12÷2,20	2,12÷2,17	1,74 min	0,90÷0,92	Specific gravity
Resistenza a trazione	DIN 53455	N/mm ²	20÷40	24÷30	40÷60	25÷33	Tensile strength
Allungamento a rottura	DIN 53455	%	250÷400	250÷300	20÷50	20÷800	Ultimate elongation
Modulo di trazione	DIN 53547	N/mm ²	750	700	2.400	1100÷1300	Tensile modulus
Resistenza alla compressione							Compressive strength
Carico di snervamento 1%	DIN 53454	N/mm ²	4,5	5			1% Yield point
Carico di snervamento 10%	DIN 53454	N/mm ²	18	20			100% Yield point
Durezza Shore	DIN 53374	Shore	55÷60	58-63	78	73	Shore hardness

Proprietà termiche

Thermal properties

Proprietà	Metodo	U.M.	PTFE	PFA	PVDF	PP	Properties
Temperatura di esercizio		°C	-30/+260	-30/+260	-12/+135	-20/+107	Temperature range
Punto di fusione	DTA	°C	-	305	178	165	Melting range
Coefficiente di espansione							Expansion coefficient
da +30°C a 100°C	DIN 53752	K ⁻¹	12·10 ⁻⁵	12·7·10 ⁻⁵			from +30°C to 100°C
da +30°C a 200°C	DIN 53752	K ⁻¹	14·10 ⁻⁵	14·10 ⁻⁵			from +30°C to 200°C
da +30°C a 300°C	DIN 53752	K ⁻¹	17·10 ⁻⁵	17·10 ⁻⁵			from +30°C to 300°C
Calore specifico							Specific heat
@ 0°C	DIN 53736	Kj/Kg·K	0,96				@ 0°C
@ 100°C	DIN 53736	Kj/Kg·K	1,03				@ 100°C
Conducibilità termica	DIN 52612	W/m·K	0,24-0,50	0,19-0,25	0,12-0,20	0,18-0,25	Thermal conductivity

Proprietà elettriche

Electrical properties

Proprietà	Metodo	U.M.	PTFE	PFA	PVDF	PP	Properties
Rigidità dielettrica	ASTM D149	Kv/mm	>20	>80	30÷60	75	Dielectric strength
Costante dielettrica	ASTM D150	1 MHz	2,1	2,1	7,5	2,3	Dielectric costant
Dissipazione	ASTM D150	1 MHz	0,0003	0,0001	0,003	0,001	Power factor
Resistività di massa	DIN 53482	Ohm·cm	10 ¹⁸	10 ¹⁸	5·10 ¹⁴	10 ¹⁷	Volume resistivity
Resistività di superficie	DIN 53482	Ohm	10 ¹⁷	10 ¹⁸	10 ¹³	10 ¹³	Surface resistivity

Spessore dei rivestimenti

Liner thickness

Lo spessore del rivestimento (PTFE, PFA) deve essere concordato in funzione delle condizioni di esercizio e comunque non deve essere inferiore a 3 mm. La normativa ASTM F1545 prevede una deviazione limite del -20% nello spessore della parte risbordata.

The liner thickness (PTFE, PFA) shall be selected depending on working conditions and shall be the subject of agreement. The lining shall have a nominal thickness of not less than 3 mm, subject to a limit deviation of -20% for the lining on the flange facing (ASTM F1545).

DN	TUBI FLANGIATI - FLANGED PIPES				
	PTFE	PTFE	PTFE	PVDF	PP
	LW mm	SW mm	HD mm	mm	mm
1/2"	3,0	-	3,0	3,0	3,0
3/4"	3,0	-	3,0	3,0	3,0
1"	3,0	-	3,3	2,7	3,2
1 1/4"	3,2	-	3,3	3,0	3,0
1 1/2"	3,3	-	3,3	2,7	4,0
2"	4,0	-	3,5	2,7	4,4
2 1/2"	4,5	-	3,5	3,0	3,0
3"	5,0	3,6	4,2	3,5	4,4
4"	5,5	4,2	4,8	3,5	5,3
5"	6,0	4,2	5,0	3,0	3,0
6"	6,0	5,0	6,5	4,0	6,5
8"	7,0	6,5	8,0	4,0	8,0
10"	7,0	6,5	9,0	3,0	3,0
12"	8,0	6,5	10,0	3,0	3,0

LW = Basso spessore
SW = Spessore standard
HD = Alto spessore

LW = Low wall thickness
SW = Standard wall
HD = Heavy Duty

DN	CURVE-ELBOW				TEE-TEES				RACCORDI-FITTINGS			
	PTFE mm	PFA mm	PVDF mm	PP mm	PTFE mm	PFA mm	PVDF mm	PP mm	PTFE mm	PFA mm	PVDF mm	PP mm
1/2"	3,0	-	-	-	-	3,0	3,0	3,0	3,0	3,0	3,0	3,0
3/4"	3,0	-	-	-	-	3,0	3,0	3,0	3,0	3,0	3,0	3,0
1"	3,0	3,0	3,0	3,0	-	3,0	3,0	3,0	3,3	3,0	3,0	3,0
1 1/4"	3,2	-	-	-	-	3,0	3,0	3,0	3,3	3,0	3,0	3,0
1 1/2"	3,3	3,5	3,5	3,5	-	3,0	3,0	3,0	3,3	3,0	3,0	3,0
2"	4,0	4,0	4,0	4,0	-	3,0	3,0	3,0	3,5	3,0	3,0	3,0
2 1/2"	4,5	-	-	-	-	3,5	3,5	3,5	3,5	3,5	3,5	3,5
3"	5,0	4,0	4,0	4,0	-	3,5	3,5	3,5	4,2	3,5	3,5	3,5
4"	5,5	4,5	4,5	4,5	-	4,5	4,5	4,5	4,8	4,5	4,5	4,5
5"	6,0	-	-	-	5,0	5,0	5,0	5,0	5,0	5,0	5,0	5,0
6"	6,0	3,0	4,5	4,5	5,0	5,0	5,0	5,0	5,0	5,0	5,0	5,0
8"	7,0	3,0	3,0	3,0	6,0	7,0	3,0	6,0	6,0	5,0	5,0	5,0
10"	7,0	3,0	3,0	3,0	7,0	-	-	3,0	7,0	3,0	-	3,0
12"	8,0	3,0	3,0	3,0	7,0	-	-	3,0	7,0	3,0	-	3,0

Esecuzioni speciali con spessori maggiorati sono disponibili a richiesta.

Thicker liners available on request.

Gli spessori dei rivestimenti sono indicativi e possono essere modificati senza preavviso.

Liner thickness are indicative, they may changed without notice.

RESISTENZA AL VUOTO

VACUUM RESISTANCE

Tubazioni

Lined flanged pipes

DN	≤ 2 1/2"	3"	3"	4"	4"	6"	6"	8"	8"	10"	10"	12"	12"
	HD	SW	HD	SW	HD	SW	HD	SW	HD	SW	HD	SW	HD
25°C	0,05	0,05	0,05	25	0,05	100	0,05	150	0,05	250	0,05	300	0,05
100°C	0,05	25	0,05	75	0,05	175	0,05	225	0,05	300	0,05	375	0,05
150°C	0,05	50	0,05	150	0,05	250	0,05	300	0,05	475	0,05	475	0,05
200°C	0,05	75	0,05	175	25	300	50	350	50	550	50	600	50
230°C	0,05	100	0,05	200	50	350	75	400	75	650	100	675	100

Curve

Lined elbows

DN	≤ 3"	4"	6"	6"	8"	8"	10"	10"	12"	12"
	HD	HD	SW	HD	SW	HD	SW	HD	SW	HD
25°C	0,05	0,05	100	0,05	150	0,05	250	0,05	300	0,05
100°C	0,05	0,05	175	0,05	225	0,05	300	0,05	375	0,05
150°C	0,05	0,05	250	0,05	300	0,05	475	0,05	475	0,05
200°C	0,05	25	300	25	350	50	550	50	600	50
230°C	0,05	50	350	50	400	75	650	100	675	100

Tee e raccordi

Lined tees and fittings

DN	≤ 3"	4"	6"	6"	8"	8"	10"	10"	12"	12"
	HD	HD	SW	HD	SW	HD	SW	HD	SW	HD
25°C	0,05	0,05	100	0,05	150	0,05	250	0,05	300	0,05
100°C	0,05	0,05	175	0,05	225	0,05	300	0,05	375	0,05
150°C	0,05	0,05	250	0,05	300	0,05	475	0,05	475	0,05
200°C	0,05	25	300	25	350	50	550	50	600	50
230°C	0,05	50	350	50	400	75	650	100	675	100

Fattori di conversione
1 Torr = 1,33 mbar = 133 Pa

Conversion factors
1 Torr = 1,33 mbar = 133 Pa

I valori riportati nelle tabelle sono espressi in Torr, variano in funzione delle condizioni di esercizio e sono comunque da ritenersi indicativi.

The table values are expressed in Torr and may change depending on conditions and in any case they are only indicative.

PRESSIONE MASSIMA DI ESERCIZIO

MAXIMUM WORKING PRESSURE

Temperatura °C	-15	50	75	100	125	150	200	250	Temperature °C
ANSI 150 lbs	15	13	12,5	12	11	10,5	9,5	8	ANSI 150 lbs
ANSI 300 lbs	34	28	27,5	26,5	24,5	22,5	19,8	16,5	ANSI 300 lbs

COLLAUDI E CERTIFICAZIONI

CONTROLLO VISIVO

Viene effettuato su tutti i particolari finiti. Il rivestimento e la risbordatura devono essere privi di incisioni, macchie, inclusioni o fessure.

CONTROLLO DIMENSIONALE

Viene effettuato su tutti i particolari finiti. Le dimensioni devono corrispondere a quelle indicate nelle tabelle mantenendo le tolleranze standard secondo ANSI B16.5.

CONTROLLO DIELETTRICO

La continuità del rivestimento viene controllata con poroscopio sul 100% dei particolari finiti. Il valore numerico della differenza di potenziale applicata U, in Kv, viene espresso con la seguente formula:

$$U = 5 \times \text{spessore del rivestimento, in mm}$$

Per spessori superiori ai 6 mm il valore U corrisponde a 35 Kv.

Il 100% dei particolari rivestiti in PVDF vengono collaudati a 15 Kv, per il PP il valore di collaudo corrisponde a 10 Kv.

CONTROLLO IDRAULICO E PNEUMATICO

Il collaudo idraulico viene eseguito a temperatura ambiente ad un valore di 1,5 volte la pressione nominale.

Il collaudo pneumatico viene eseguito, nel rispetto delle normative di sicurezza, immergendo completamente i particolari in acqua e mantenendo la pressione per almeno 3 minuti.

Collaudi secondo la normativa ASTM F-423 e F-781 (pressioni maggiorate) vengono eseguiti soltanto se precedentemente concordati.

MARCATURA ED IDENTIFICAZIONE

Tutti i particolari finiti sono marcati secondo ASTM F1545 con i seguenti dati:

Marchio del costruttore
Diametro e pressione nominale
Simbolo di identificazione del rivestimento
Specifica ASTM di riferimento "ASTM F1545"
Simbolo "Ω" per rivestimenti in fluoropolimeri conduttivi

Le lunghezze dei tubi sono indicate con inchiostro indelebile. Identificazioni diverse vengono eseguite a richiesta.

RINTRACCIABILITÀ TOTALE

Oltre alla marcatura secondo ASTM F1545, su ogni particolare viene stampigliato un codice progressivo per l'identificazione dei materiali costruttivi e della data di produzione.

CERTIFICATI

A richiesta, e con sovrapprezzo, vengono forniti i certificati secondo la normativa EN 10204. I certificati devono essere richiesti prima dell'inizio della produzione.

TESTING AND CERTIFICATION

VISUAL CHECK

All finished pieces, liner and flared parts are checked for any spot, inclusions, cracks or bad workmanship.

DIMENSIONAL CHECK

All finished pieces are checked: dimensions must be the same as those indicated in the tables, maintaining normal tolerance standards according to ANSI B16.5

DIELECTRIC CHECK

The lining shall be checked for continuity by means of spark testing. The numerical value of the test voltage, U, in kV, shall be one per five mm of lining thickness :

$$U = 5 \times \text{liner thickness, in mm.}$$

In case the liner is higher than 6 mm , the test voltage shall be 35 Kv.

All PVDF lined finished products are checked at 15 Kv, PP lined ones are checked at 10 Kv.

HYDRAULIC AND PNEUMATIC CHECK

Hydrostatic testing shall be carried out on lined pipes and fittings at ambient temperature. Hydrostatic test pressure shall be equal to 1,5 times the allowable working pressure, in bar. For testing with air, the relevant safety specifications shall be complied with. Within the scope of pressure testing with air, the tightness of flanged pipes and fittings shall be checked by immersing them in water at least for 3 minutes. Pressure testing according to ASTM F-423 and F-781 (increased pressure) are only carried out according to agreements.

MARKING

All finished products are marked with the following information according to ASTM F1545:

*The lining manufacturer's mark
Nominal size and pressure
Symbol denoting lining material
ASTM designation
The symbol "Ω" for lining that is not electrostatically chargeable*

Flanged pipe lengths are marked with permanent ink. Other marking available on request.

TRACEABILITY

All parts are marked with an identification code number. Which allows us to retrieve material and process information.

CERTIFICATION

EN 10204 certificates are available at additional cost. Certificates must be requested before start of manufacture.

protel®

Prima della spedizione tutte le superfici di tenuta vengono preservate da eventuali danneggiamenti con tappi di protezione. Tali coperture possono essere rimosse esclusivamente per un'ispezione, per il collaudo o per l'installazione e devono essere riapplicate dopo il controllo.

L'imbragatura e l'equipaggiamento per il sollevamento non deve essere situato all'interno di un particolare rivestito in quanto danneggerebbe il rivestimento.

Non si possono effettuare saldature sulle superfici d'acciaio già rivestite internamente.

Guarnizioni supplementari in PTFE devono essere utilizzate in caso di serraggio tra rivestimenti diversi o qualora si effettuino frequenti montaggi e smontaggi.

In caso di utilizzo sotto vuoto il valore della forza di serraggio dei bulloni dovrà essere aumentato di ca. 15%.

Una forza di serraggio troppo elevata comporta una deformazione della superficie di tenuta.

Dopo 24-30 ore od un ciclo di temperatura o di pressione il valore della forza di serraggio di ciascun bullone deve essere controllato ed eventualmente riportato al valore consigliato.

Before being shipped, all sealing surfaces are protected with end-covers, that should only be removed for inspection, testing or installation. End-covers must be replaced again after inspection.

Sling and or lifting equipment must not be placed inside a lined item because of possible damage to liner.

No welding is permitted on the metal housing after liner is in place.

Auxiliary PTFE envelope gaskets must be used when flanging lined items to flanges of dissimilar materials. Otherwise, gaskets are not required except when repeated connections and disconnections are to be made.

Vacuum service increases the value of bolting torque by ca. 15%.

Excessive bolting torque can cause deformation of the seal-surface.

After 24-30 hours or a temperature cycle or a pressure cycle, each bolt must be checked and re-torqued to the recommended value.

Forza di serraggio consigliata per flange ANSI classe 150 lbs.

Recommended bolt torques for flanges ANSI class 150 lbs.

DN	PTFE ft-lb	PFA ft-lb	PVDF ft-lb	PP ft-lb	Bulloni - Bolts n x inch
1/2"	10	10	-	-	4 x 1/2"
3/4"	10	10	-	-	4 x 1/2"
1"	10	10	17	13	4 x 1/2"
1 1/4"	19	19	-	-	4 x 1/2"
1 1/2"	19	19	41	31	4 x 1/2"
2"	39	39	85	65	4 x 1/2"
2 1/2"	39	39	-	-	4 x 5/8"
3"	62	62	134	103	4 x 5/8"
4"	40	40	88	67	8 x 5/8"
5"	45	45	-	-	8 x 3/4"
6"	75	75	161	124	8 x 3/4"
8"	100	100	217	167	8 x 3/4"
10"	94	94	204	157	12 x 7/8"
12"	116	116	251	193	12 x 7/8"

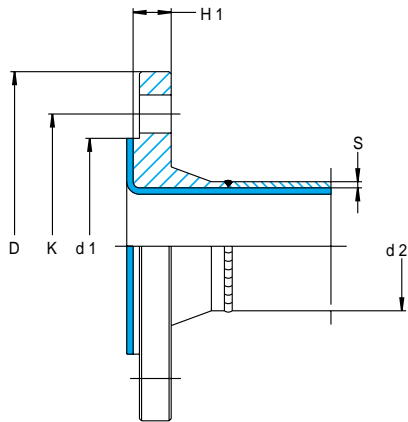

Welding Neck

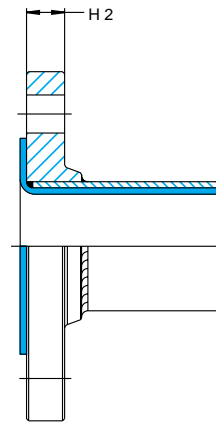

Slip On

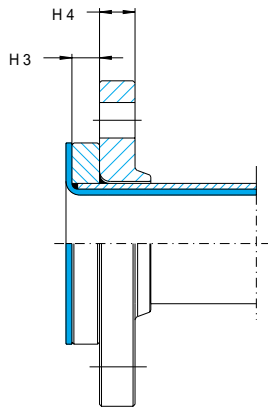

Lap Joint with collar

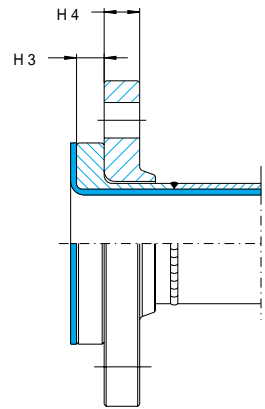

Lap Joint with stub end

ANSI B16.5 - 150 lbs.

DN	D mm	k mm	d1 mm	Fori-Holes nxØmm	d2xs mm	Viti-Bolts Ømm	H1 mm	H2 mm	H3 mm	H4 mm
1/2"	88,9	60,3	35	4 x 15,9	26,7x2,87	1/2"	11,1	11,1	10	11,1
3/4"	98,4	69,8	43	4 x 15,9	26,7x2,87	1/2"	12,7	12,7	12	12,7
1"	107,9	79,4	51	4 x 15,9	33,4x3,38	1/2"	14,3	14,3	12	14,3
1 1/4"	117,5	88,9	64	4 x 15,9	42,4x3,56	1/2"	15,9	15,9	12	15,9
1 1/2"	127,0	98,4	73	4 x 15,9	48,3x3,68	1/2"	17,5	17,5	12	17,5
2"	152,4	120,6	92	4 x 19,0	60,3x3,91	5/8"	19,0	19,0	14	19,0
2 1/2"	117,8	139,7	105	4 x 19,0	73,0x5,16	5/8"	22,2	22,2	14	22,2
3"	190,5	152,4	127	4 x 19,0	88,9x5,49	5/8"	23,8	23,8	16	23,8
4"	228,6	190,5	158	8 x 19,0	114,3x6,02	5/8"	23,8	23,8	16	23,8
5"	254,0	215,9	186	8 x 22,2	139,7x6,55	3/4"	23,8	23,8	18	23,8
6"	279,4	241,3	216	8 x 22,2	168,3x7,11	3/4"	25,4	25,4	18	25,4
8"	342,9	298,4	270	8 x 22,2	219,1x6,35	3/4"	28,6	28,6	20	28,6
10"	406,4	361,9	324	8 x 25,4	273,0x6,35	7/8"	30,2	30,2	22	30,2
12"	482,6	431,8	381	8 x 25,4	323,8x7,1	7/8"	31,7	31,7	22	31,7

Altre dimensioni a richiesta

Other sizes available on request

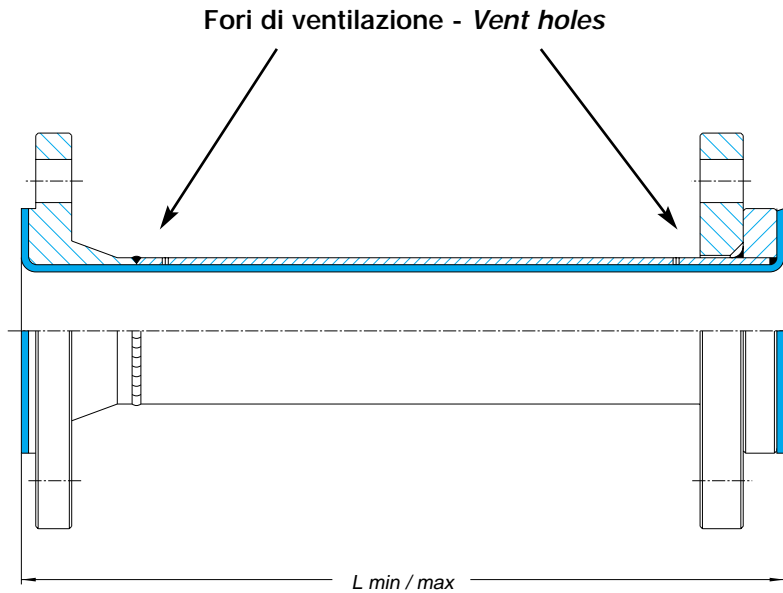

ANSI B16.5 - 150 lbs.

DN	L min. mm	L max. mm	PTFE		PVDF	PP
			SW	HD	HD	HD
1/2"	85	3000	-	●	-	-
3/4"	100	3000	-	●	-	-
1"	100	6000	-	●	●	●
1 1/4"	100	6000	-	●	-	-
1 1/2"	105	6000	-	●	●	●
2"	115	6000	-	●	●	●
2 1/2"	115	6000	-	●	-	-
3"	125	6000	●	●	●	●
4"	135	6000	●	●	●	●
5"	140	3000	●	●	-	-
6"	145	3000	●	●	●	●
8"	150	3000	●	●	●	●
10"	175	3000	●	●	●	●
12"	175	3000	●	●	●	●

DN 1/2" non normalizzato secondo ASME/ANSI B36.10
 Altre dimensioni a richiesta

DN 1/2" not according to ASME/ANSI B36.10
 Other sizes available on request

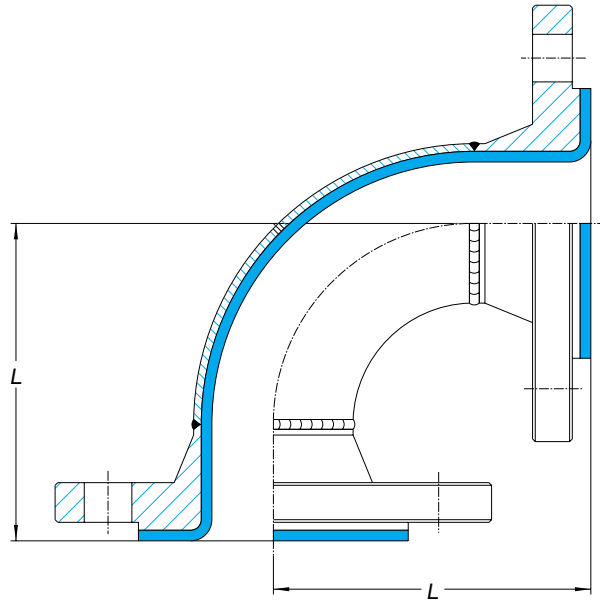

ANSI B16.5 - 150 lbs.

DN	L mm	PTFE		PFA		PVDF		PP	
		SW	HD	HD	HD	HD	HD		
1/2" ¹	65	-	●	-	-	-	-	-	-
3/4"	75	-	●	-	-	-	-	-	-
1"	89	-	●	●	●	●	●	●	●
1 1/4"	95	-	●	-	-	-	-	-	-
1 1/2"	102	-	●	●	●	●	●	●	●
2"	114	-	●	●	●	●	●	●	●
2 1/2"	127	-	●	-	-	-	-	-	-
3"	140	-	●	●	●	●	●	●	●
4"	165	-	●	●	●	●	●	●	●
5"	190	●	●	-	-	-	-	-	-
6"	203	●	●	●	●	●	●	●	●
8"	229	●	●	●	●	●	●	●	●
10"	279	●	●	-	-	-	-	-	-
12"	305	●	●	-	-	-	-	-	-

1) Corpo centrale DN 3/4"

1) Central body DN 3/4"

Flangia fissa-libera o 2 flange libere a richiesta
Altre dimensioni a richiesta

Fixed-loose flange or 2 loose flanges available on request
Other sizes available on request

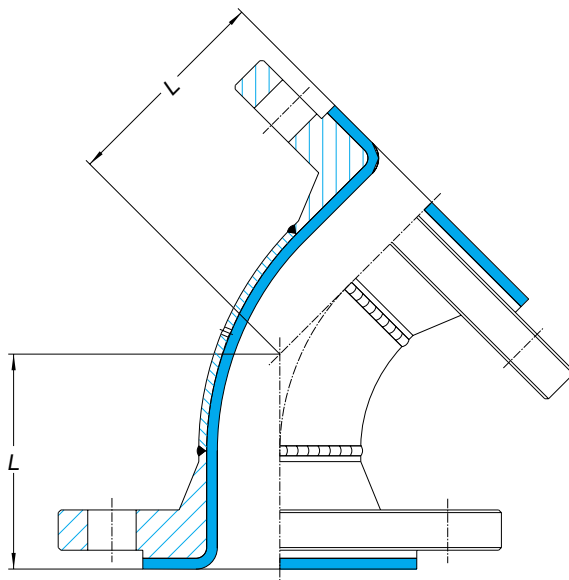

ANSI B16.5 - 150 lbs.							
DN	L mm	SW	PTFE		PFA	PVDF	PP
			HD	HD	HD	HD	
1/2" ¹	45	-	●	-	-	-	-
3/4"	45	-	●	-	-	-	-
1"	45	-	●	●	●	●	●
1 1/4"	51	-	●	-	-	-	-
1 1/2"	57	-	●	●	●	●	●
2"	64	-	●	●	●	●	●
2 1/2"	76	-	●	-	-	-	-
3"	76	-	●	●	●	●	●
4"	102	-	●	●	●	●	●
5"	114	●	●	-	-	-	-
6"	127	●	●	●	●	●	●
8"	140	●	●	●	●	●	●
10"	165	●	●	-	-	-	-
12"	190	●	●	-	-	-	-

1) Corpo centrale DN 3/4"

1) Central body DN 3/4"

Flangia fissa-libera o 2 flange libere a richiesta
Altre dimensioni a richiesta

Fixed-loose flange or 2 loose flanges available on request
Other sizes available on request

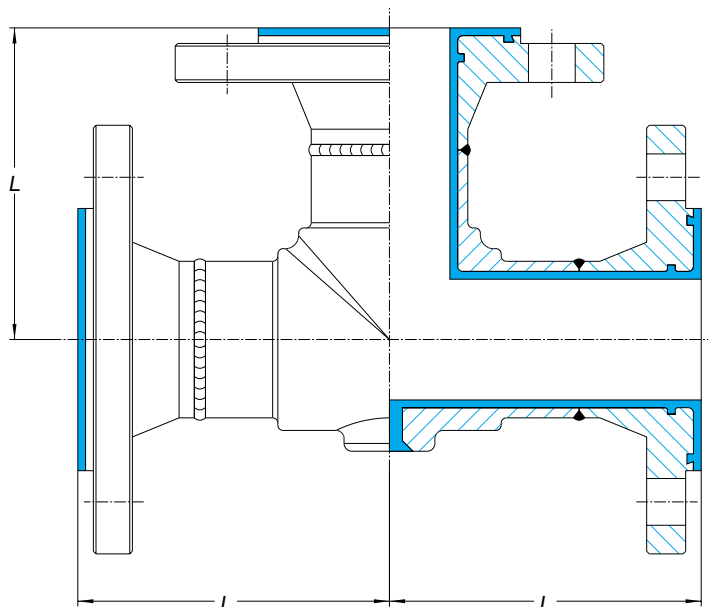

ANSI B16.5 - 150 lbs.

DN	L mm	PTFE		PFA	PVDF	PP
		SW	HD	HD	HD	HD
1/2" ¹	65	-	-	●	●	●
3/4"	75	-	-	●	●	●
1"	89	-	-	●	●	●
1 1/4"	95	-	-	●	●	●
1 1/2"	102	-	-	●	●	●
2"	114	-	-	●	●	●
2 1/2"	127	-	-	●	●	●
3"	140	-	-	●	●	●
4"	165	-	-	●	●	●
5"	190	●	●	●	●	●
6"	203	●	●	●	●	●
8"	229	●	●	-	●	●
10"	279	●	●	-	-	-
12"	305	●	●	-	-	-

1) Corpo centrale DN 3/4"

Flangia fissa-libera o 2 flange libere a richiesta
Altre dimensioni a richiesta

1) Central body DN 3/4"

Fixed-loose flange or 2 loose flanges available on request
Other sizes available on request

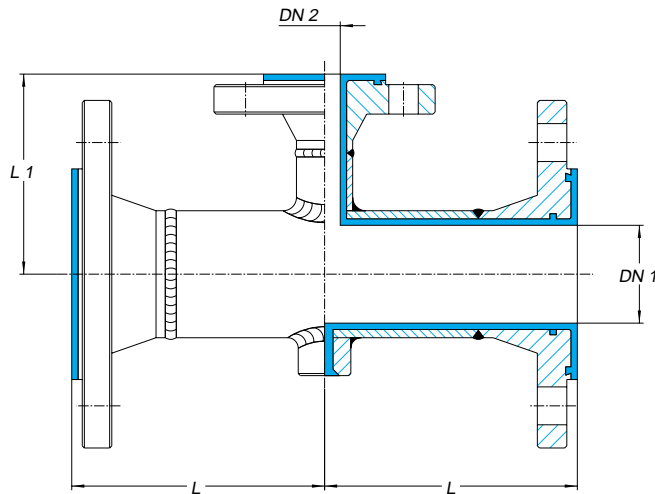

ANSI B16.5 - 150 lbs.

DN1	DN2	L mm	L1 mm	PTFE		PFA	PVDF	PP
				SW	HD	HD	HD	HD
3/4"	1/2" 1)	75	75	-	-	●	●	●
1"	1/2" 1)	89	89	-	-	●	●	●
	3/4"	89	89	-	-	●	●	●
1 1/4"	1"	95	95	-	-	●	●	●
1 1/2"	3/4"	102	102	-	-	●	●	●
	1"	102	102	-	-	●	●	●
2"	1"	114	114	-	-	●	●	●
	1 1/2"	114	114	-	-	●	●	●
2 1/2"	1"	127	127	-	-	●	●	●
	1 1/2"	127	127	-	-	●	●	●
	2"	127	127	-	-	●	●	●
3"	1"	140	140	-	-	●	●	●
	1 1/2"	140	140	-	-	●	●	●
	2"	140	140	-	-	●	●	●

1) Tubo DN 3/4"

1) Pipe DN 3/4"

Flangia fissa + 2 libere o 3 flange libere a richiesta
Altre dimensioni a richiesta

Fixed + 2 loose flanges or 3 loose flanges available on request
Other sizes available on request

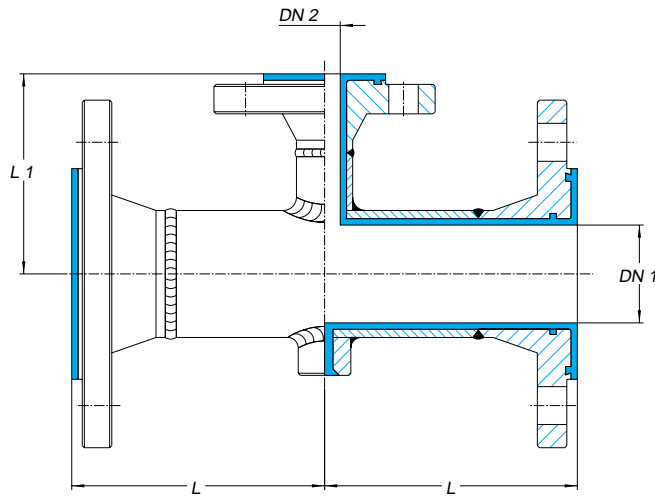

ANSI B16.5 - 150 lbs.

DN1	DN2	L mm	L1 mm	PTFE		PFA	PVDF	PP
				SW	HD	HD	HD	HD
4"	1"	165	165	-	-	●	●	●
	1 1/2"	165	165	-	-	●	●	●
	2"	165	165	-	-	●	●	●
	3"	165	165	-	-	●	●	●
5"	2"	190	190	●	●	●	●	●
	3"	190	190	●	●	●	●	●
6"	2"	203	203	●	●	●	●	●
	3"	203	203	●	●	●	●	●
	4"	203	203	●	●	●	●	●
8"	3"	229	229	●	●	●	●	●
	4"	229	229	●	●	●	●	●
	6"	229	229	●	●	●	●	●
10"	4"	279	279	●	●	-	-	-
	6"	279	279	●	●	-	-	-
	8"	279	279	●	●	-	-	-
12"	6"	305	305	●	●	-	-	-
	8"	305	305	●	●	-	-	-
	10"	305	305	●	●	-	-	-

Flangia fissa + 2 libere o 3 flange libere a richiesta
 Altre dimensioni a richiesta

Fixed + 2 loose flanges or 3 loose flanges available on request
 Other sizes available on request

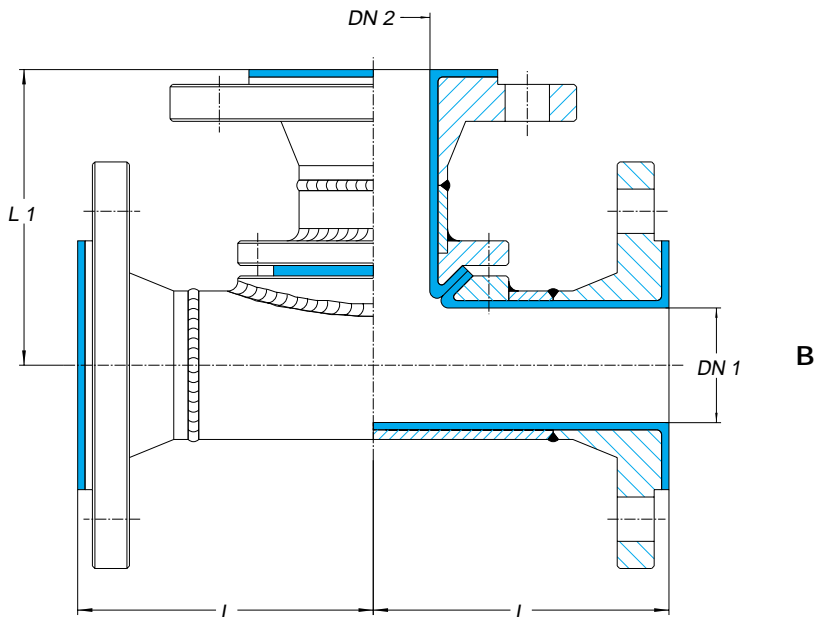
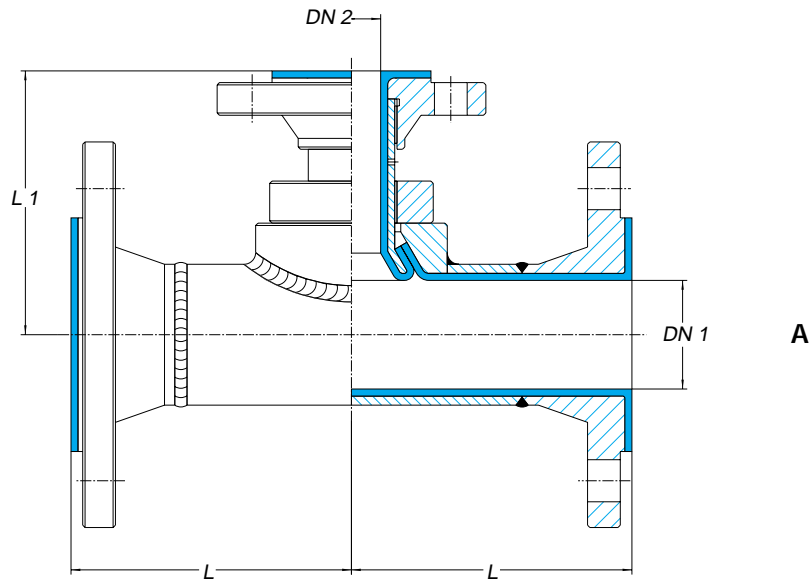

ANSI B16.5 - 150 lbs.

DN1	DN2	TIPO TYPE	L mm	L1 mm	PTFE		PFA HD	PVDF HD	PP HD
					SW	HD			
8"	3"	A	229	229	●	●	-	-	-
	4"	A	229	229	●	●	-	-	-
	6"	B	229	229	●	●	-	-	-
10"	4"	A	279	279	●	●	-	-	-
	6"	B	279	279	●	●	-	-	-
	8"	B	279	279	●	●	-	-	-
12"	6"	B	305	305	●	●	-	-	-
	8"	B	305	305	●	●	-	-	-
	10"	B	305	305	●	●	-	-	-

Flangia fissa + 2 libere o 3 flange libere a richiesta
Altre dimensioni a richiesta

Fixed + 2 loose flanges or 3 loose flanges available on request
Other sizes available on request

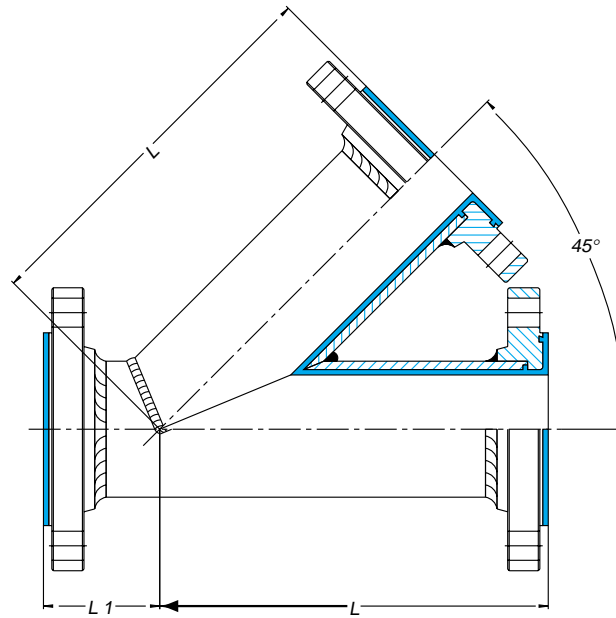

ANSI B16.5 - 150 lbs.

DN	L mm	L1 mm	SW	PTFE HD	PFA HD	PVDF HD	PP HD
1/2"	-	-	-	-	-	-	-
3/4"	-	-	-	-	-	-	-
1"	146	45	☞	☞	●	☞	●
1 1/4"	-	-	-	-	-	-	-
1 1/2"	178	51	☞	☞	●	☞	●
2"	203	64	☞	☞	●	☞	●
2 1/2"	-	-	-	-	-	-	-
3"	254	76	☞	☞	●	☞	●
4"	305	76	☞	☞	●	☞	●
5"	-	-	-	-	-	-	-
6"	368	89	☞	☞	☞	-	☞
8"	-	-	-	-	-	-	-
10"	-	-	-	-	-	-	-
12"	-	-	-	-	-	-	-

Altre dimensioni a richiesta

Other sizes available on request

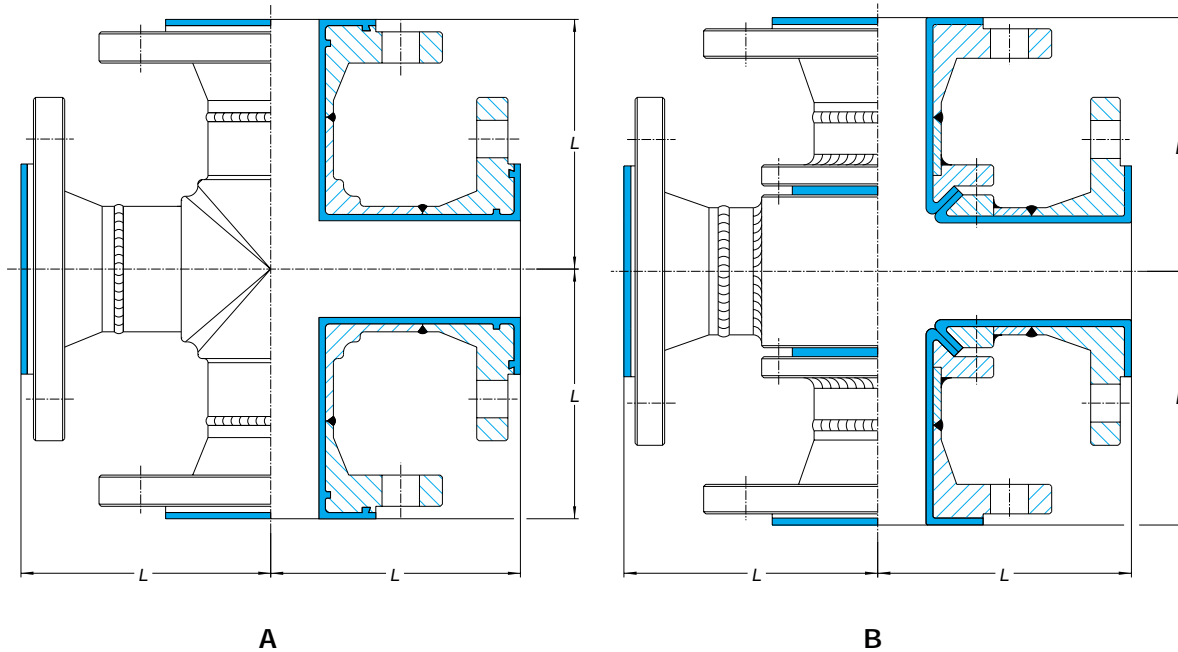

ANSI B16.5 - 150 lbs.

DN	L mm	TIPO TYPE	PTFE		PFA	PVDF	PP
			SW	HD	HD	HD	HD
1/2" ¹	65	A	-	●	●	●	●
3/4"	75	A	-	●	●	●	●
1"	89	A	-	●	●	●	●
1 1/4"	95	A	-	●	●	●	●
1 1/2"	102	A	-	●	●	●	●
2"	114	A	-	●	●	●	●
2 1/2"	127	A	-	●	●	●	●
3"	140	A	-	●	●	●	●
4"	165	A	-	●	●	●	●
5"	190	A-B	●	●	●	●	●
6"	203	A-B	●	●	●	●	●
8"	229	A-B	●	●	●	●	●
10"	279	A-B	●	●	-	-	-
12"	305	A-B	●	●	-	-	-

1) Corpo centrale DN 3/4"

2 flange fisse + 2 libere o 4 flange libere a richiesta
Altre dimensioni a richiesta

1) Central body DN 3/4"

2 fixed+2 loose flanges or 4 loose flanges available on request
Other sizes available on request

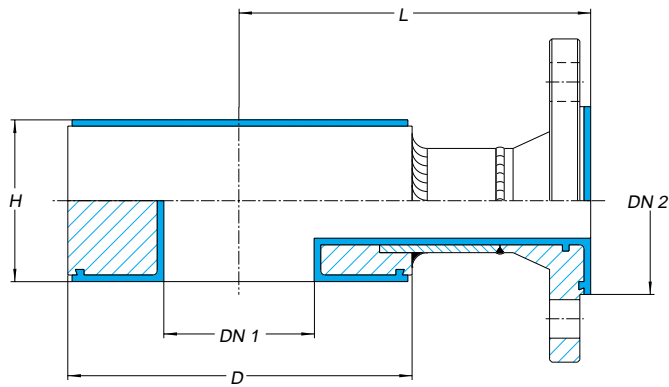

ANSI B16.5 - 150 lbs.

DN1	DN2	D	H	L	PFA	PVDF	PP
		mm	mm	mm	HD	HD	HD
1"	3/4"	55	51	89	●	◐	●
	1"	55	51	89	●	◐	●
1 1/4"	1"	68	51	95	●	◐	●
1 1/2"	1"	75	51	102	●	◐	●
	1 1/2"	75	75	102	●	◐	●
2"	1"	95	51	114	●	◐	●
	1 1/2"	95	75	114	●	◐	●
	2"	95	90	114	●	◐	●
2 1/2"	1"	108	51	127	●	◐	●
	1 1/2"	108	75	127	●	◐	●
	2"	108	90	127	●	◐	●
3"	1"	130	51	140	●	◐	●
	1 1/2"	130	75	140	●	◐	●
	2"	130	90	140	●	◐	●

Esecuzione speciale con 2 o 3 stacchi laterali a richiesta
 Altre dimensioni a richiesta

Special design with 2 or 3 branches available on request
 Other sizes available on request

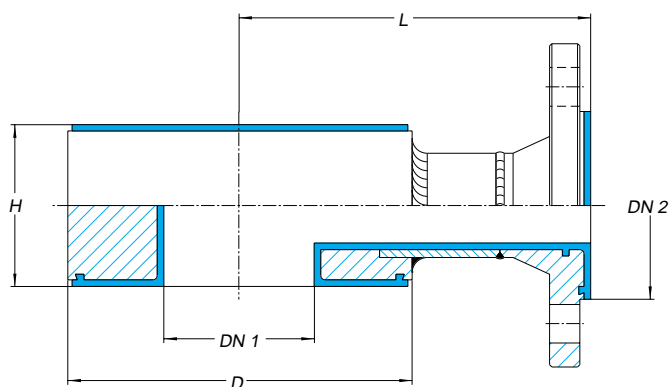

ANSI B16.5 - 150 lbs.

DN1	DN2	D	H	L	PFA	PVDF	PP
		mm	mm	mm	HD	HD	HD
4"	1"	162	51	165	●	●	●
	1 1/2"	162	75	165	●	●	●
	2"	162	90	165	●	●	●
5"	1"	190	51	190	●	●	●
	1 1/2"	190	75	190	●	●	●
	2"	190	90	190	●	●	●
6"	1"	218	51	203	●	●	●
	1 1/2"	218	75	203	●	●	●
	2"	218	90	203	●	●	●
8"	1"	273	51	229	●	●	●
	1 1/2"	273	75	229	●	●	●
	2"	273	90	229	●	●	●
10"	1"	336	51	279	●	●	●
	1 1/2"	336	75	279	●	●	●
	2"	336	90	279	●	●	●
12"	1"	406	90	305	●	●	●
	1 1/2"	406	110	305	●	●	●
	2"	406	120	305	●	●	●

Esecuzione speciale con 2 o 3 stacchi laterali a richiesta
Altre dimensioni a richiesta

Special design with 2 or 3 branches available on request
Other sizes available on request

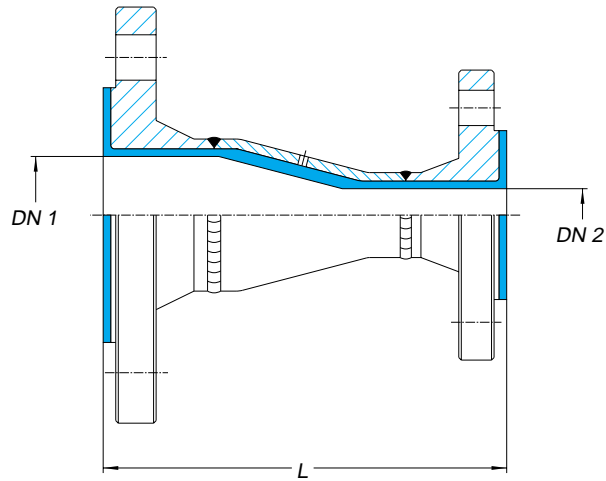

ANSI B16.5 - 150 lbs.								
DN1	DN2	L	PTFE	PFA	PVDF	PP	SW	HD
		mm						
3/4"	1/2" ¹	114	-	●	●	●	-	●
1"	3/4"	114	-	●	●	●	-	●
	1/2" ¹	114	-	●	●	●	-	●
1/4"	1"	114	-	●	●	●	-	●
	3/4"	114	-	-	●	●	-	●
1 1/2"	1/4"	114	-	●	●	●	-	●
	1"	114	-	-	●	●	-	●
	3/4"	114	-	-	●	●	-	●
2"	1 1/2"	127	-	●	●	●	-	●
	1 1/4"	127	-	-	●	●	-	●
	1"	127	-	-	●	●	-	●
2 1/2"	2"	140	-	●	●	●	-	●
	1 1/2"	140	-	-	●	●	-	●
	1"	140	-	-	●	●	-	●
3"	2 1/2"	152	-	●	●	●	-	●
	2"	152	-	-	●	●	-	●
	1 1/2"	152	-	-	●	●	-	●
4"	3"	178	-	●	●	●	-	●
	2 1/2"	178	-	-	●	●	-	●
	2"	178	-	-	●	●	-	●

1) Tubo DN 3/4"

1) Pipe DN 3/4"

Altre dimensioni a richiesta

Other sizes available on request

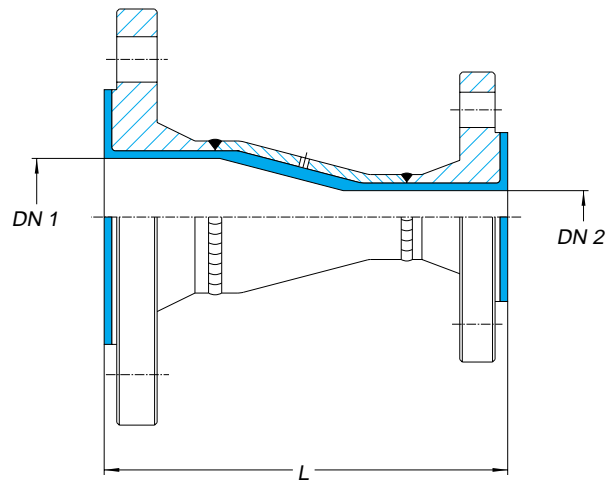

ANSI B16.5 - 150 lbs.								
DN1	DN2	L		PTFE		PFA	PVDF	PP
		mm	SW		HD	HD	HD	HD
5"	4"	203	-		●	●	●	●
	3"	203	-		-	●	●	●
	2 1/2"	203	-		-	●	●	●
6"	5"	229	-		●	●	●	●
	4"	229	-		-	●	●	●
	3"	229	-		-	●	●	●
8"	6"	279	●		-	●	●	●
	5"	279	●		-	●	●	●
	4"	279	●		-	●	●	●
10"	8"	305	●		-	●	●	●
	6"	305	●		-	●	●	●
	5"	305	●		-	●	●	●
12"	10"	356	●		-	●	●	●
	8"	356	●		-	●	●	●
	6"	356	●		-	●	●	●

Altre dimensioni a richiesta

Other sizes available on request

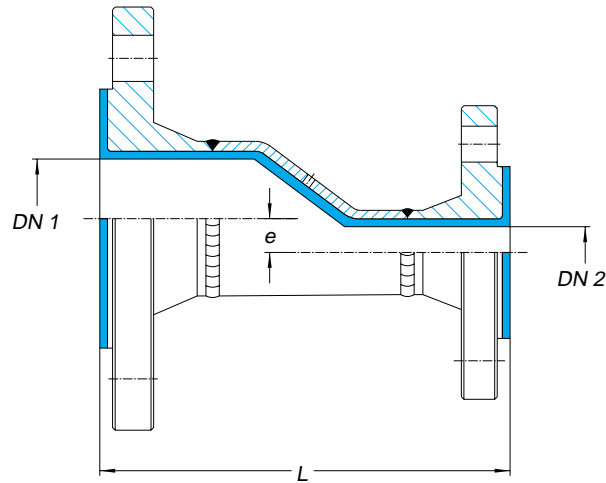

ANSI B16.5 - 150 lbs.

DN1	DN2	L mm	e mm	SW	PTFE		PFA	PVDF	PP
						HD	HD	HD	HD
3/4"	1/2" ¹	114		-		●	●	◐	●
1"	3/4"	114	4	-		●	●	◐	●
	1/2" ¹	114		-		●	●	◐	●
1 1/4"	1"	114	4	-		●	●	◐	●
	3/4"	114		-		-	●	◐	●
1 1/2"	1 1/4"	114	3	-		●	●	◐	●
	1"	114	7	-		-	●	◐	●
	3/4"	114		-		-	●	◐	●
2"	1 1/2"	127	6	-		●	●	◐	●
	1 1/4"	127	9	-		-	●	◐	●
	1"	127	13	-		-	●	◐	●
2 1/2"	2"	140	8	-		●	●	◐	●
	1 1/2"	140	14	-		-	●	◐	●
	1"	140		-		-	●	◐	●
3 1/2"	2 1/2"	152	6	-		●	●	◐	●
	2"	152	14	-		-	●	◐	●
	1 1/2"	152	20	-		-	●	◐	●
4"	3"	178	13	-		●	●	◐	●
	2 1/2"	178	19	-		-	●	◐	●
	2"	178	27	-		-	●	◐	●

1) Tubo DN 3/4"

1) Pipe DN 3/4"

Altre dimensioni a richiesta

Other sizes available on request

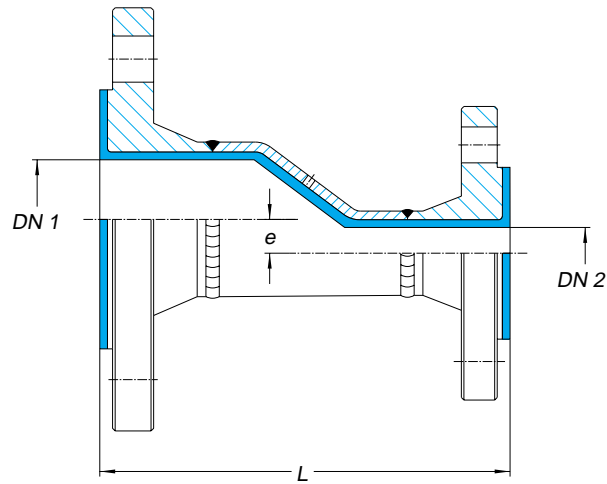

ANSI B16.5 - 150 lbs.

DN1	DN2	L	e	PTFE	PFA	PVDF	PP
		mm	mm	SW	HD	HD	HD
5"	4"	203	13	-	●	●	●
	3"	203	25	-	-	●	●
	2 1/2"	203	32	-	-	●	●
6"	5"	229	14	-	●	●	●
	4"	229	27	-	-	●	●
	3"	229	40	-	-	●	●
8"	6"	279	25	●	-	●	●
	5"	279	40	●	-	●	●
	4"	279	52	●	-	●	●
10"	8"	305	27	●	-	●	●
	6"	305	52	●	-	●	●
	5"	305	67	●	-	●	●
12"	10"	356	25	●	-	●	●
	8"	356	52	●	-	●	●
	6"	356	78	●	-	●	●

Altre dimensioni a richiesta

Other sizes available on request

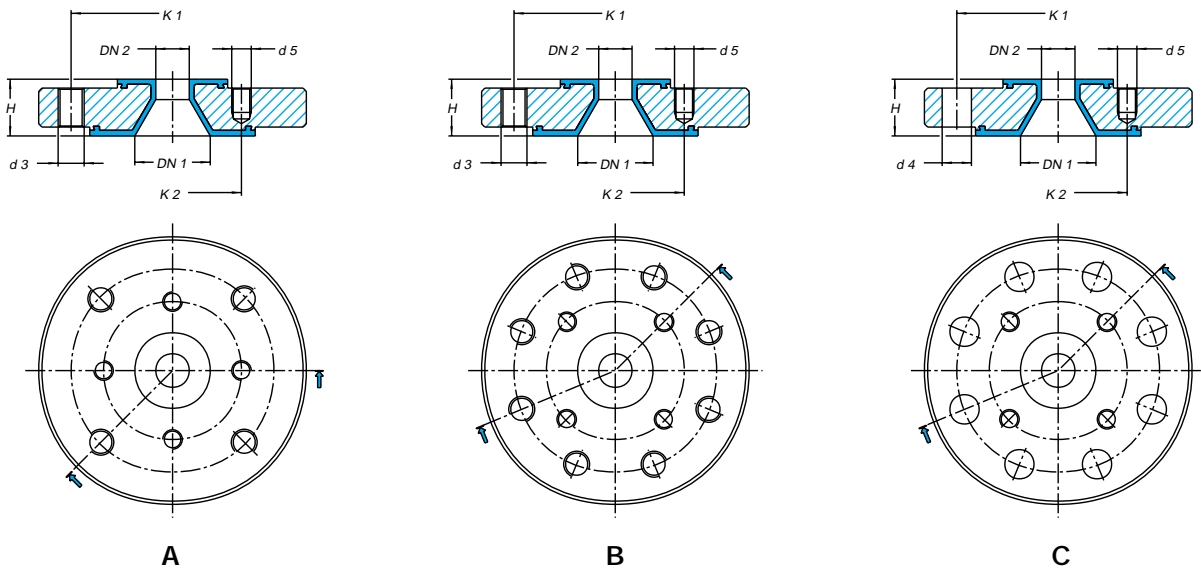

ANSI B16.5 - 150 lbs.

DN1	DN2	H	Typo	k1	DN1	DN2	PTFE-PFA	PVDF	PP
		mm	Type		nxd3	nxd4	HD	HD	HD
3/4"	1/2"	35	A	69,8	4 x 1/2"	-	●	●	●
1"	1/2"	35	A	79,4	4 x 1/2"	-	●	●	●
	3/4"	35	A	79,4	4 x 1/2"	-	●	●	●
1 1/4"	1/2"	35	A	88,9	4 x 1/2"	-	●	●	●
	3/4"	35	A	88,9	4 x 1/2"	-	●	●	●
	1"	35	A	88,9	4 x 1/2"	-	●	●	●
1 1/2"	1/2"	35	B	98,4	4 x 1/2"	-	●	●	●
	3/4"	35	A	98,4	4 x 1/2"	-	●	●	●
	1"	35	A	98,4	4 x 1/2"	-	●	●	●
	1 1/4"	35	A	98,4	4 x 1/2"	-	●	●	●
2"	1/2"	35	B	120,6	4 x 5/8"	-	●	●	●
	3/4"	35	B	120,6	4 x 5/8"	-	●	●	●
	1"	35	B	120,6	4 x 5/8"	-	●	●	●
	1 1/4"	35	A	120,6	4 x 5/8"	-	●	●	●
	1 1/2"	35	A	120,6	4 x 5/8"	-	●	●	●
2 1/2"	3/4"	35	C	139,7	-	4 x 19	●	●	●
	1"	35	C	139,7	-	4 x 19	●	●	●
	1 1/4"	35	B	139,7	4 x 5/8"	-	●	●	●
	1 1/2"	35	B	139,7	4 x 5/8"	-	●	●	●
	2"	35	A	139,7	4 x 5/8"	-	●	●	●
3"	3/4"	35	C	152,4	-	4 x 19	●	●	●
	1"	35	C	152,4	-	4 x 19	●	●	●
	1 1/4"	35	B	152,4	4 x 5/8"	-	●	●	●
	1 1/2"	35	B	152,4	4 x 5/8"	-	●	●	●
	2"	35	A	152,4	4 x 5/8"	-	●	●	●
	2 1/2"	35	A	152,4	4 x 5/8"	-	●	●	●

Altre dimensioni a richiesta

Other sizes available on request

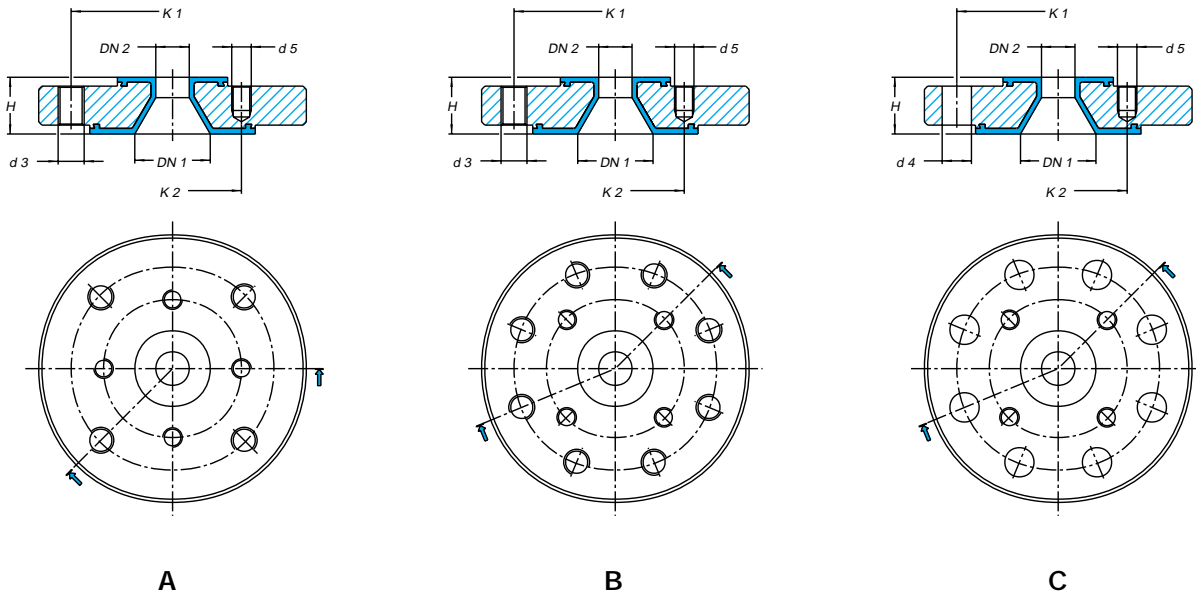

ANSI B16.5 - 150 lbs.

DN1	DN2	H	Tipo	DN1	DN2	PTFE-PFA	PVDF	PP			
		mm	Type	k1	nxd3	nxd4	k2	nxd5	HD	HD	HD
4"	3/4"	45	C	190,5	-	8 x 19	60,3	4 x 1/2"	●	●	●
	1"	45	C	190,5	-	8 x 19	79,4	4 x 1/2"	●	●	●
	1 1/4"	45	C	190,5	-	8 x 19	88,9	4 x 1/2"	●	●	●
	1 1/2"	45	C	190,5	-	8 x 19	98,4	4 x 1/2"	●	●	●
	2"	45	B	190,5	8 x 5/8"	-	120,6	4 x 5/8"	●	●	●
	2 1/2"	45	B	190,5	8 x 5/8"	-	139,7	4 x 5/8"	●	●	●
	3"	45	B	190,5	8 x 5/8"	-	152,4	4 x 5/8"	●	●	●
5"	1"	45	C	215,9	-	8 x 22,2	79,4	4 x 1/2"	●	●	●
	1 1/4"	45	C	215,9	-	8 x 22,2	88,9	4 x 1/2"	●	●	●
	1 1/2"	45	C	215,9	-	8 x 22,2	98,4	4 x 1/2"	●	●	●
	2"	45	C	215,9	-	8 x 22,2	120,6	4 x 5/8"	●	●	●
	2 1/2"	45	B	215,9	-	-	139,7	4 x 5/8"	●	●	●
	3"	45	B	215,9	8 x 3/4"	-	152,4	4 x 5/8"	●	●	●
	4"	45	A	215,9	8 x 3/4"	-	190,5	8 x 5/8"	●	●	●
6"	1"	45	C	241,3	-	8 x 22,2	79,4	4 x 1/2"	●	●	●
	1 1/4"	45	C	241,3	-	8 x 22,2	88,9	4 x 1/2"	●	●	●
	1 1/2"	45	C	241,3	-	8 x 22,2	98,4	4 x 1/2"	●	●	●
	2"	45	C	241,3	-	8 x 22,2	120,6	4 x 5/8"	●	●	●
	2 1/2"	45	C	241,3	-	8 x 22,2	139,7	4 x 5/8"	●	●	●
	3"	45	C	241,3	-	8 x 22,2	152,4	4 x 5/8"	●	●	●
	4"	45	B	241,3	8 x 3/4"	-	190,5	8 x 5/8"	●	●	●
5"	45	A	241,3	8 x 3/4"	-	215,9	8 x 3/4"	●	●	●	

Altre dimensioni a richiesta

Other sizes available on request

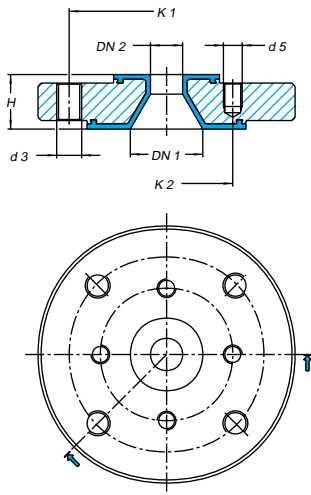

A

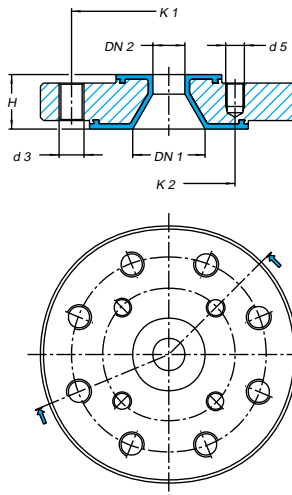

B

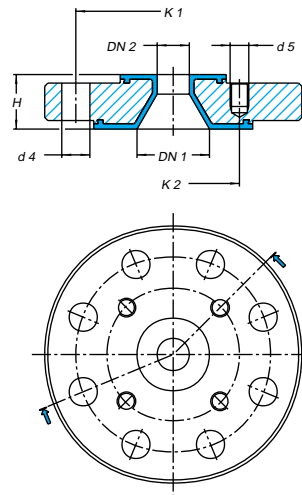

C

ANSI B16.5 - 150 lbs.

DN1	DN2	H	Tipo		DN1	DN2	PTFE-PFA	PVDF	PP		
		mm	Type	k1	nxd3	nxd4	HD	HD	HD		
8"	1"	45	C	298,4	-	8 x 22,2	79,4	4 x 1/2"	●	●	●
	1 1/2"	45	C	298,4	-	8 x 22,2	98,4	4 x 1/2"	●	●	●
	2"	45	C	298,4	-	8 x 22,2	120,6	4 x 5/8"	●	●	●
	2 1/2"	45	C	298,4	-	8 x 22,2	139,7	4 x 5/8"	●	●	●
	3"	45	C	298,4	-	8 x 22,2	152,4	4 x 5/8"	●	●	●
	4"	45	C	298,4	-	8 x 22,2	190,5	8 x 5/8"	●	●	●
	5"	45	C	298,4	-	8 x 22,2	215,9	8 x 3/4"	●	●	●
6"	45	B	298,4	298,4	8 x 3/4"	-	241,3	8 x 3/4"	●	●	●
10"	2"	45	C	361,9	-	12 x 25,4	120,6	4 x 5/8"	●	●	●
	2 1/2"	45	C	361,9	-	12 x 25,4	139,7	4 x 5/8"	●	●	●
	3"	45	C	361,9	-	12 x 25,4	152,4	4 x 5/8"	●	●	●
	4"	45	C	361,9	-	12 x 25,4	190,5	8 x 5/8"	●	●	●
	5"	45	C	361,9	-	12 x 25,4	215,9	8 x 3/4"	●	●	●
	6"	45	C	361,9	-	12 x 25,4	241,3	8 x 3/4"	●	●	●
	8"	45	B	361,9	361,9	12 x 7/8"	-	298,4	8 x 3/4"	●	●
12"	2"	50	C	431,8	-	12 x 25,4	120,6	4 x 5/8"	●	●	●
	2 1/2"	50	C	431,8	-	12 x 25,4	139,7	4 x 5/8"	●	●	●
	3"	50	C	431,8	-	12 x 25,4	152,4	4 x 5/8"	●	●	●
	4"	50	C	431,8	-	12 x 25,4	190,5	8 x 5/8"	●	●	●
	5"	50	C	431,8	-	12 x 25,4	215,9	8 x 3/4"	●	●	●
	6"	50	C	431,8	-	12 x 25,4	241,3	8 x 3/4"	●	●	●
	8"	50	C	431,8	-	12 x 25,4	298,4	8 x 3/4"	●	●	●
	10"	50	B	431,8	431,8	12 x 7/8"	-	361,9	12 x 7/8"	●	●

Altre dimensioni a richiesta

Other sizes available on request

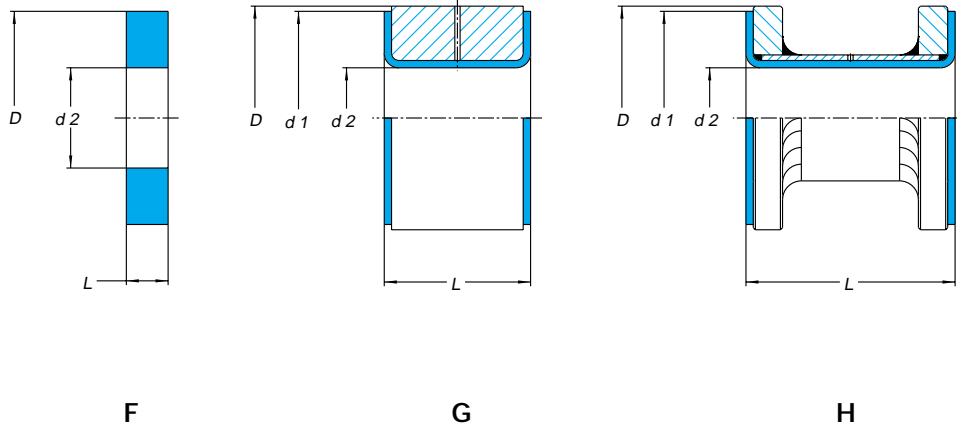

ANSI B16.5 - 150 lbs.

DN	D mm	d1 mm	d2 mm	F	G	H	PTFE HD	PVDF HD	PP HD
				L mm	L mm	L mm			
1/2"	40	35	15	5÷20	10÷50	60÷100	●	◐	●
3/4"	50	43	15	5÷20	10÷50	60÷100	●	◐	●
1"	55	51	21	5÷20	10÷50	60÷100	●	◐	●
1 1/4"	68	64	28	5÷20	10÷50	60÷100	●	◐	●
1 1/2"	75	73	34	5÷20	10÷50	60÷100	●	◐	●
2"	95	92	46	5÷20	10÷50	60÷100	●	◐	●
2 1/2"	108	105	56	5÷20	10÷50	60÷100	●	◐	●
3"	130	127	70	5÷20	10÷60	70÷100	●	◐	●
4"	162	158	94	5÷20	15÷60	70÷100	●	◐	●
5"	190	186	122	5÷20	15÷70	80÷100	●	◐	●
6"	218	216	144	5÷20	20÷70	80÷100	●	◐	●
8"	273	270	194	5÷20	20÷70	80÷100	●	◐	●
10"	336	324	247	5÷20	20÷70	80÷100	●	◐	●
12"	406	381	298	5÷20	20÷70	80÷100	●	◐	●

Altre dimensioni a richiesta

Other sizes available on request

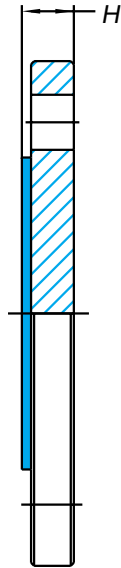

ANSI B16.5 - 150 lbs.							
DN	H mm	SW	PTFE		PFA	PVDF	PP
				HD	HD	HD	HD
1/2"	14	-		●	-	☞	●
3/4"	16	-		●	-	☞	●
1"	17	-		●	-	☞	●
1 1/4"	19	-		●	-	☞	●
1 1/2"	20	-		●	-	☞	●
2"	22	-		●	-	☞	●
2 1/2"	25	-		●	-	☞	●
3"	28	-		●	-	☞	●
4"	28	-		●	-	☞	●
5"	28	-		●	-	☞	●
6"	30	-		●	-	☞	●
8"	33	-		●	-	☞	●
10"	35	-		●	-	☞	●
12"	37	-		●	-	☞	●

Altre dimensioni a richiesta

Other sizes available on request

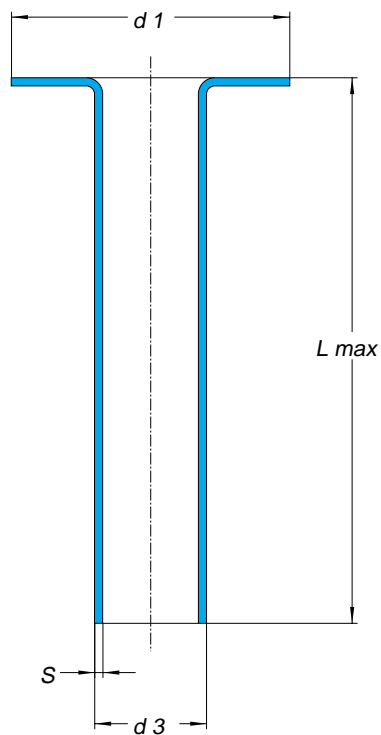

ANSI B16.5 - 150 lbs.

DN	d1 mm	d3 mm (± 5%)	s mm	L max mm	PTFE SW
1/2"	35	12	3,0	3000	●
3/4"	43	15	3,0	3000	●
1"	51	20	3,0	3000	●
1 1/4"	64	28	3,0	3000	●
1 1/2"	73	32	3,0	3000	●
2"	92	41	3,0	3000	●
2 1/2"	105	56	3,5	3000	●
3"	127	66	3,5	3000	●
4"	158	94	4,0	3000	●
5"	186	117	4,0	3000	●
6"	216	139	5,0	3000	●
8"	270	182	6,0	3000	●
10"	324	231	7,0	3000	●
12"	381	288	7,0	3000	●

Altre dimensioni a richiesta

Other sizes available on request

PESCANTI rivestiti PTFE
(Acciaio spessore standard)

PTFE lined DIP-PIPES
(Standard thickness steel)

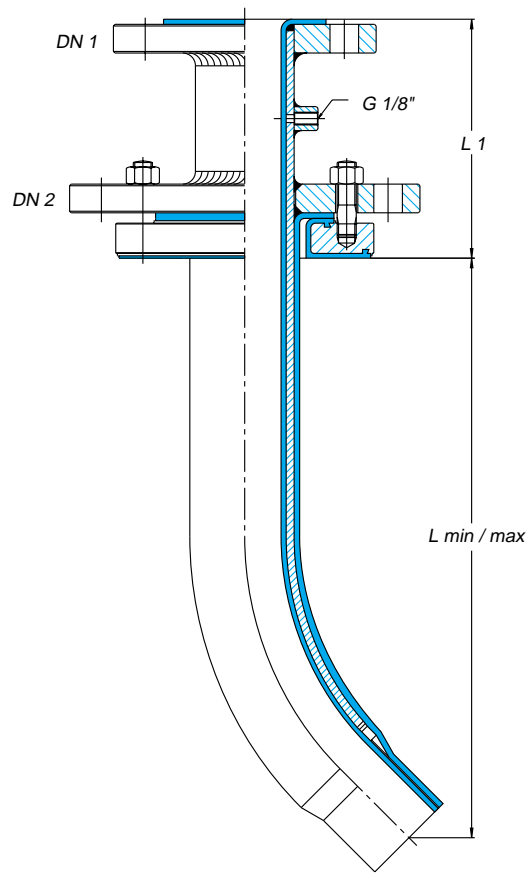
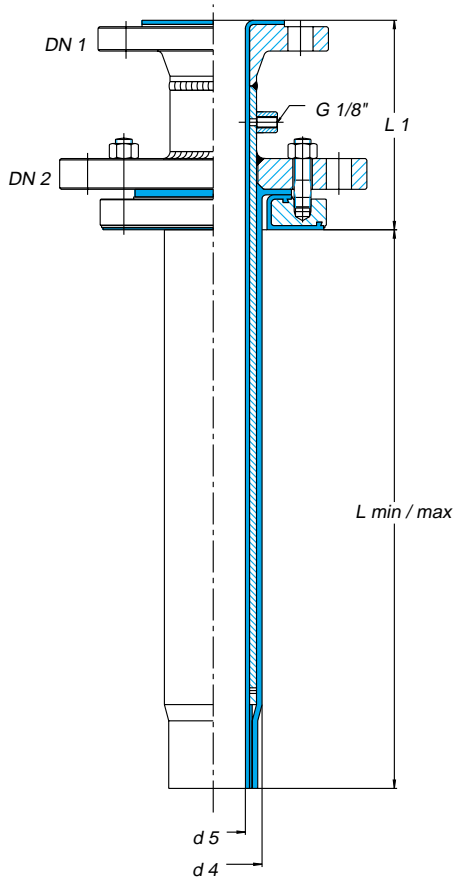

Flange secondo ANSI B16.5 classe 150 lbs.

Flanges according to ANSI 16.5 class 150 lbs.

DN1	DN2	Acciaio-Steel mm	d4 mm	d5 mm	L1 mm	L min mm	L max mm	PTFE
1/2"	1 1/2" ÷ 2"	32 x 3	38	20	150	150	5800	●
3/4"	1 1/2" ÷ 6"	32 x 3	38	20	150	150	5800	●
1"	1 1/2" ÷ 6"	32 x 3	38	20	150	150	5800	●
1 1/4"	1 1/2"	32 x 3	38	20	150	150	5800	●
	2" ÷ 6"	38 x 3	44	26	150	150	5800	●
1 1/2"	2"	38 x 3	44	26	150	150	5800	●
	2 1/2" ÷ 8"	48,3 x 3,68	55	35	150	150	5800	●
2"	2 1/2"	48,3 x 3,68	55	35	150	150	5800	●
	3" ÷ 10"	62 x 5	71	45	150	150	5800	●
2 1/2"	3"	62 x 5	71	45	150	200	5700	●
	4" ÷ 10"	73 x 5,16	84	56	150	200	5700	●
3"	4" ÷ 12"	88,9 x 5,49	98	70	150	200	5700	●
4"	5" ÷ 12"	114,3 x 6,02	124	93	150	200	5700	●
6"	8" ÷ 12"	168,3 x 7,1	178	147	150	300	3000	●

Altre dimensioni a richiesta

Other sizes available on request

**PESCANTI rivestiti PTFE
(Acciaio alto spessore)**

**PTFE lined DIP-PIPES
(High thickness steel)**

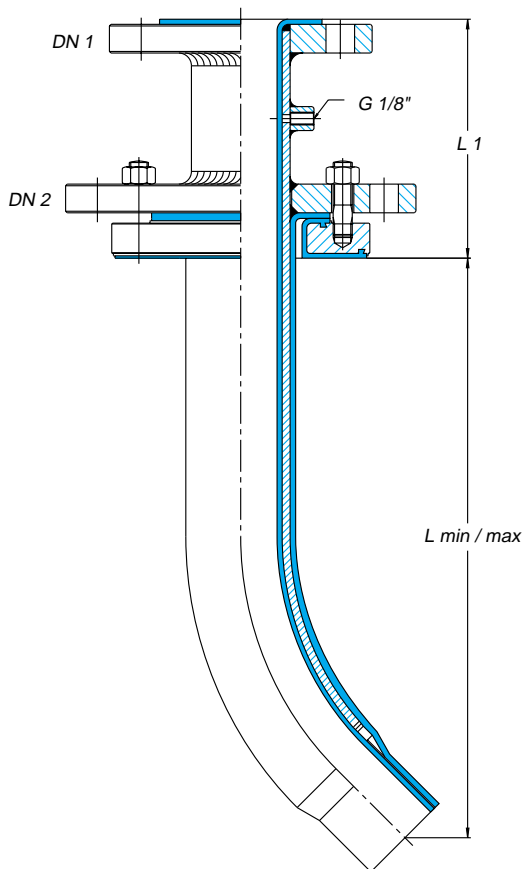
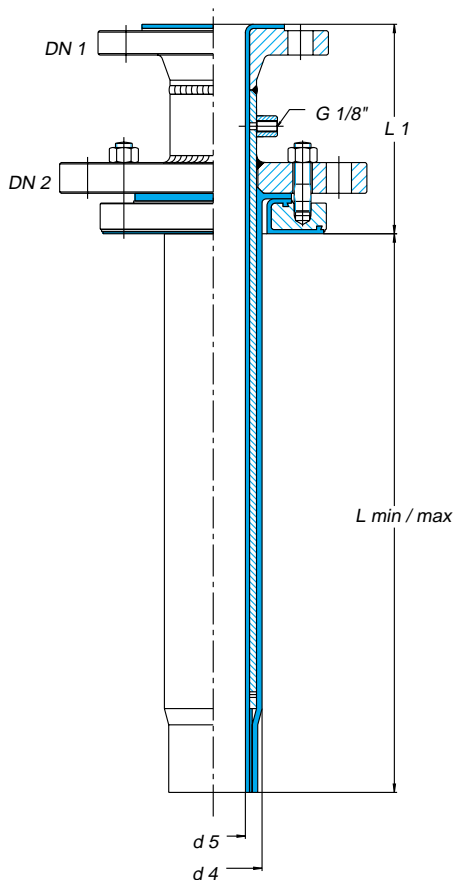

Flange secondo ANSI B16.5 classe 150 lbs.

Flanges according to ANSI B16.5 class 150 lbs.

DN1	DN2	Acciaio-Steel mm	d4 mm	d5 mm	L1 mm	L min mm	L max mm	PTFE
1/2"	2"	38 x 5	44	22	150	150	5800	●
3/4"	2"÷6"	38 x 5	44	22	150	150	5800	●
1"	2"÷6"	38 x 5	44	22	150	150	5800	●
1 1/4"	2"	38 x 5	44	22	150	150	5800	●
	2 1/2"÷6"	48 x 8	55	26	150	150	5800	●
1 1/2"	2 1/2"	48 x 8	55	26	150	150	5800	●
	3"÷8"	63 x 10	71	37	150	150	5800	●
2"	3"	63 x 10	71	37	150	150	5800	●
	4"÷10"	73 x 9,52	84	47	150	150	5800	●
2 1/2"	4"÷10"	88,9 x 11,1	98	60	150	200	5700	●
3"	4"	88,9 x 11,1	98	60	150	200	5700	●
	5"÷12"	100 x 10	110	72	150	200	5700	●
4"	6"÷12"	127 x 12,5	135	93	150	200	5700	●
6"	8"÷12"	168,3 x 17,5	178	123	150	300	3000	●

Altre dimensioni a richiesta

Other sizes available on request

protef®

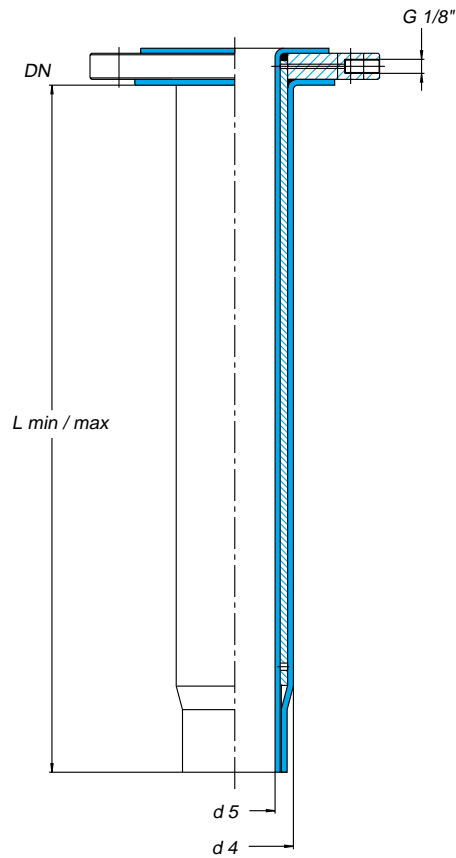

Flange secondo ANSI B16.5 classe 150 lbs.

Flanges according to ANSI 16.5 class 150 lbs.

DN	Acciaio-Steel mm	d4 mm	d5 mm	L min mm	L max mm	PTFE
1"	22 x 2,5	29	11	150	3000	●
1 1/4"	32 x 3	38	20	150	3000	●
1 1/2"	38 x 3	44	26	150	3000	●
2"	48,3 x 3,68	55	35	150	3000	●
2 1/2"	62 x 5	71	45	200	3000	●
3"	73 x 5,16	84	56	200	3000	●
4"	88,9 x 5,49	98	70	200	3000	●
6"	139,7 x 4	154	124	300	3000	●

Altre dimensioni a richiesta

Other sizes available on request

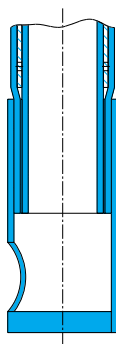

A

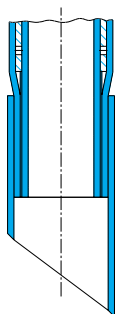

B

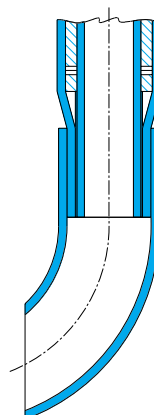

C

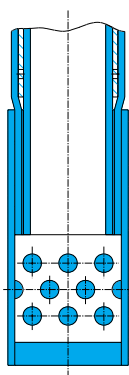

D

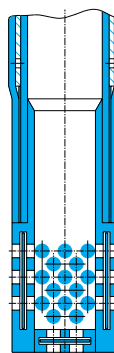

F

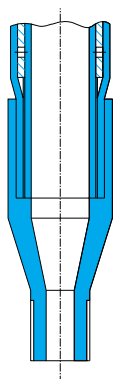

G

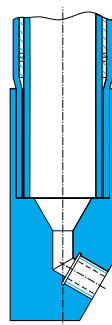

H

Altri diffusori a richiesta

Other distributors available on request

COMPENSATORI 2 onde

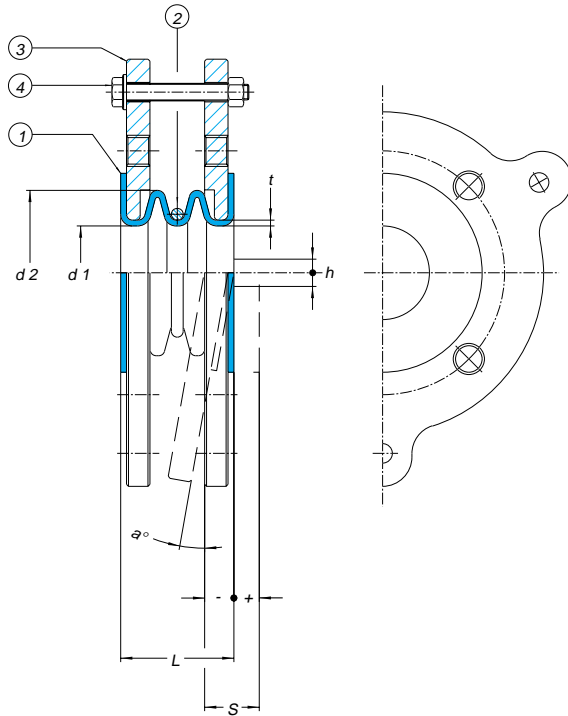

1	PTFE vergine secondo ASTM D 4895
1.1	PTFE conduttibile a richiesta
2	AISI 304
2.1	Hastelloy C4 a richiesta
3	ASTM A216 WCB o ASTM A105 zincato
3.1	AISI 304 o AISI 316 a richiesta
4	Viti e dadi zincati
4.1	AISI 304 o AISI 316 a richiesta

EXPANSION JOINTS 2 convolutions

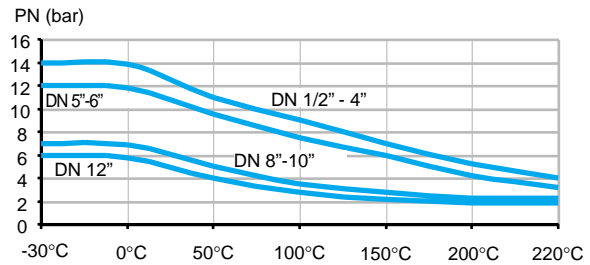

Flange secondo ANSI B16.5 classe 150 lbs.
Fattore di sicurezza \approx 4:1

Flanges according to ANSI B16.5 class 150 lbs.
Safety factor \approx 4:1

1	Virgin PTFE according to ASTM D 4895
1.1	Conductive PTFE on request
2	304 SS
2.1	Hastelloy C4 on request
3	ASTM A216 WCB or ASTM A105 zinc plated flanges
3.1	304 SS or 316 on request
4	Zinc plated bolting
4.1	304 SS or 316 bolting on request

DN	L	t	d1	d2	Movimenti-Movements			Vuoto-Vacuum Fori-Holes		
					Assiale Axial	Laterale Lateral	Angolare Angular	Torr@	°C	n x ø
	$\pm 2\%$ mm	$\pm 10\%$ mm	$\pm 5\%$ mm	$\pm 5\%$ mm	s(\pm mm)	h(mm)	a(max)			
1/2" ¹	28	2,0	18	34	4	2	7°	10	200	4 x 1/2"
3/4"	28	2,0	18	34	4	2	7°	10	200	4 x 1/2"
1"	35	3,0	24	43	6	3	7°	10	200	4 x 1/2"
1 1/4" ²	35	3,0	36	57	6	3	7°	10	200	4 x 1/2"
1 1/2"	35	3,03	36	57	6	3	7°	10	200	4 x 1/2"
2"	40	3,0	50	75	6	3	7°	10	200	4 x 5/8"
2 1/2"	57	3,0	60	91	9	5	7°	10	200	4 x 5/8"
3"	57	3,5	76	104	9	5	7°	10	200	4 x 5/8"
4"	67	4,0	100	134	13	6	7°	10	200	8 x 5/8"
5"	83	4,3	122	163	13	6	7°	10	150	8 x 3/4"
6"	75	4,5	150	188	13	6	7°	10	150	8 x 3/4"
8"	102	5,3	204	250	13	6	7°	10	50	8 x 3/4"
								150	150	
10"	140	5,3	255	325	15	6	7°	60	45	12 x 7/8"
								260	100	
12"	150	5,5	280	345	20	10	7°	120	45	12 x 7/8"
								500	100	

1) Corpo centrale DN 3/4"
2) Corpo centrale DN 1 1/2"

Flange con fori passanti ed altre dimensioni a richiesta

1) Central body DN 3/4"
2) Central body DN 1 1/2"

Flange with through holes and other sizes available on request

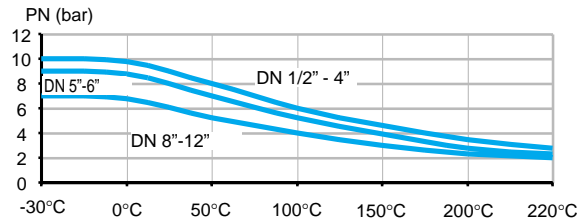
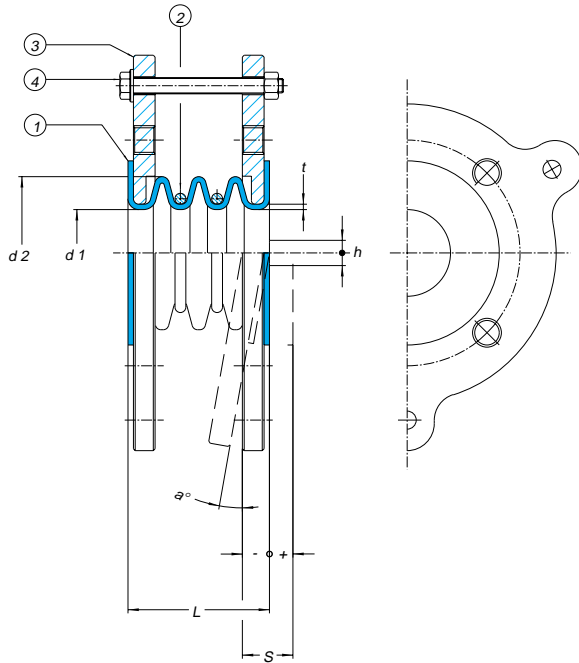

Flange secondo ANSI B16.5 classe 150 lbs.
Fattore di sicurezza ≈ 4:1

Flanges according to ANSI B16.5 class 150 lbs.
Safety factor ≈ 4:1

1	PTFE vergine secondo ASTM D 4895
1.1	PTFE conduttibile a richiesta
2	AISI 304
2.1	Hastelloy C4 a richiesta
3	ASTM A216 WCB o ASTM A105 zincato
3.1	AISI 304 o AISI 316 a richiesta
4	Viti e dadi zincati
4.1	AISI 304 o AISI 316 a richiesta

1	Virgin PTFE according to ASTM D 4895
1.1	Conductive PTFE on request
2	304 SS
2.1	Hastelloy C4 on request
3	ASTM A216 WCB or ASTM A105 zinc plated flanges
3.1	304 SS or 316 on request
4	Zinc plated bolting
4.1	304 SS or 316 bolting on request

DN	L	t	d1	d2	Movimenti-Movements			Vuoto-Vacuum Fori-Holes		
					Assiale Axial	Laterale Lateral	Angolare Angular	Torr@	°C	n x ø
	±2% mm	±10% mm	±5% mm	±5% mm	s(±mm)	h(mm)	a(max)			
1/2" 1	37	2,0	18	34	6	4	14°	10	200	4 x 1/2"
3/4"	37	2,0	18	34	6	4	14°	10	200	4 x 1/2"
1"	46	3,0	24	43	13	6	14°	10	200	4 x 1/2"
1 1/4" 2	50	3,0	36	57	13	6	14°	10	200	4 x 1/2"
1 1/2"	50	3,03	36	57	13	6	14°	10	200	4 x 1/2"
2"	56	3,0	50	75	15	9	14°	10	200	4 x 5/8"
2 1/2"	77	3,0	60	91	19	9	14°	10	200	4 x 5/8"
3"	77	3,5	76	104	25	13	14°	10	200	4 x 5/8"
4"	91	4,0	100	134	25	13	14°	10	200	8 x 5/8"
5"	111	4,3	122	163	25	14	14°	10	150	8 x 3/4"
6"	101	4,5	150	188	28	14	14°	10	150	8 x 3/4"
8"	137	5,3	204	250	28	14	14°	10	50	8 x 3/4"
								150	150	
10"	200	5,3	255	325	30	14	14°	60	45	12 x 7/8"
								260	100	
12"	196	5,5	280	345	30	15	14°	120	45	12 x 7/8"
								500	1000	

1) Corpo centrale DN 3/4"
2) Corpo centrale DN 1 1/2"
Flange con fori passanti ed altre dimensioni a richiesta

1) Central body DN 3/4"
2) Central body DN 1 1/2"
Flange with through holes and other sizes available on request

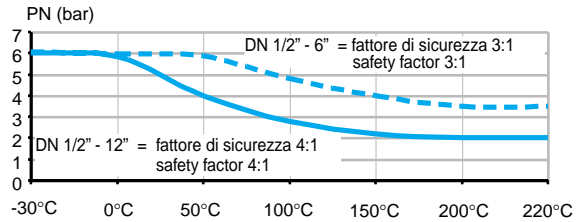
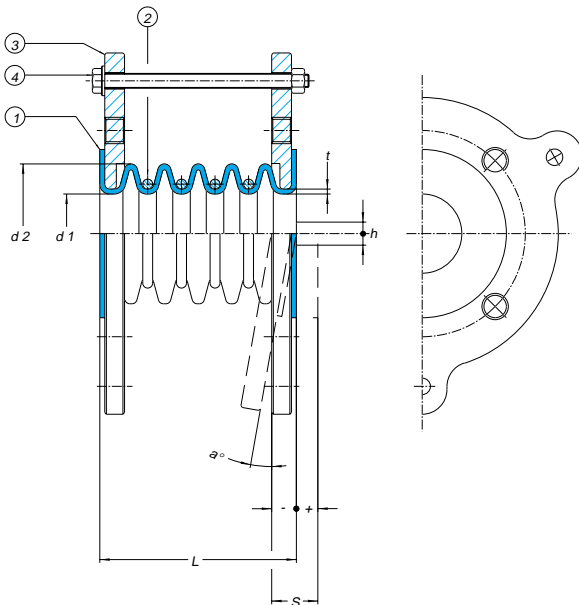

Flange secondo ANSI B16.5 classe 150 lbs.
Non consigliato per vuoto

Flanges according to ANSI B16.5 class 150 lbs.
Not recommended for vacuum service

1	PTFE vergine secondo ASTM D 4895
1.1	PTFE conduttibile a richiesta
2	AISI 304
2.1	Hastelloy C4 a richiesta
3	ASTM A216 WCB o ASTM A105 zincato
3.1	AISI 304 o AISI 316 a richiesta
4	Viti e dadi zincati
4.1	AISI 304 o AISI 316 a richiesta

1	Virgin PTFE according to ASTM D 4895
1.1	Conductive PTFE on request
2	304 SS
2.1	Hastelloy C4 on request
3	ASTM A216 WCB or ASTM A105 zinc plated flanges
3.1	304 SS or 316 on request
4	Zinc plated bolting
4.1	304 SS or 316 bolting on request

DN	L	t	d1	d2	Movimenti-Movements			Fori-Holes
					Assiale Axial s(±mm)	Laterale Lateral h(mm)	Angolare Angular a(max)	
1/2" ¹	±2% 55 mm	±10% 2,0 mm	±5% 18 mm	±5% 34 mm	8	5	20°	n x ø 4 x 1/2"
3/4"	55	2,0	18	34	8	5	20°	4 x 1/2"
1"	68	3,0	24	43	13	12	20°	4 x 1/2"
1 1/4" ²	80	3,0	36	57	19	12	20°	4 x 1/2"
1 1/2"	80	3,03	36	57	19	12	20°	4 x 1/2"
2"	88	3,0	50	75	25	12	20°	4 x 5/8"
2 1/2"	117	3,0	60	91	25	13	20°	4 x 5/8"
3"	117	3,5	76	104	25	16	20°	4 x 5/8"
4"	139	4,0	100	134	32	16	20°	8 x 5/8"
5"	167	4,3	122	163	32	16	20°	8 x 3/4"
6"	153	4,5	150	188	32	16	20°	8 x 3/4"
8"	207	5,3	204	250	32	16	20°	8 x 3/4"
10"	300	5,3	255	325	15	6	20°	12 x 7/8"
12"	288	5,5	280	345	20	10	20°	12 x 7/8"

1) Corpo centrale DN 3/4"
2) Corpo centrale DN 1 1/2"
Flange con fori passanti ed altre dimensioni a richiesta

1) Central body DN 3/4"
2) Central body DN 1 1/2"
Flange with through holes and other sizes available on request